	GLOBAL STANDARD	Page 1 of 24
	Protection and control device for HV/MV substation – Communication profile (according to IEC 61850) for the MFP remote input/output module (MFP-RIO)	<b>GSTP104</b> Rev. 01 06/12/2018

### **Protection and control device for HV/MV substation – Communication profile (according to IEC 61850) for the MFP remote input/output module (MFP-RIO)**

This global standard defines the characteristics of communication profile (according to IEC 61850 series) for the Remote Input/Output module (according to GSTP102) for HV/MV distribution substations a declared fundamental frequency of 50 Hz or 60 Hz.

Countries' I&N	Elaborated by	Collaborations by	Verified by	Approved by
Argentina	-	-	-	<b>Carlos Espinoza</b>
Brazil	-	-	-	<b>Romulo Thardelly</b>
Chile	-	-	-	<b>Daniel Gonzalez</b>
Colombia	-	-	-	<b>Juan Gomez</b>
Iberia	-	-	<b>Carmen Ranea Angel Corchero</b>	<b>Maria Avery</b>
Italy	<b>Luca Delli Carpini</b>	-	<b>Luca Delli Carpini</b>	<b>Gianluca Sapienza</b>
Peru	-	-	-	<b>Robert Sanchez</b>
Romania	-	-	-	<b>Vasilica Obrejan</b>

	Elaborated by	Collaborations by	Verified by	Approved by
<b>Global I&amp;N – NTI</b>	-	-	<b>Christian Noce</b>	<b>Fabio Giammanco</b>

This document is intellectual property of Enel Spa; reproduction or distribution of its contents in any way or by any means whatsoever is subject to the prior approval of the above mentioned company which will safeguard its rights under the civil and penal codes.

It is for internal Use. Each Country can provide a translation in local language but the official reference document is this GS English version.

Revision	Data	List of modifications
00	27.07.2018	First draft
01	06.12.2018	First approved edition

	GLOBAL STANDARD	Page 2 of 24
	Protection and control device for HV/MV substation – Communication profile (according to IEC 61850) for the MFP remote input/output module (MFP-RIO)	<b>GSTP104</b> Rev. 01 06/12/2018

## INDEX

<b>1</b>	<b>ACRONYSM</b>	<b>4</b>
<b>2</b>	<b>LIST OF COMPONENTS, PRODUCT FAMILY OR SOLUTIONS TO WHICH THE GS APPLIES</b>	<b>5</b>
<b>3</b>	<b>NORMATIVE REFERENCES AND BIBLIOGRAPHY</b>	<b>6</b>
3.1	For all countries	6
<b>4</b>	<b>REPLACED STANDARDS</b>	<b>7</b>
<b>5</b>	<b>APPLICATION FIELDS</b>	<b>8</b>
<b>6</b>	<b>FEATURES OF THE RIO</b>	<b>9</b>
6.1	Functional description	9
6.1.1	Communication via LAN in the DS	9
6.1.2	Communication via dedicated/direct connections with the MFP	9
6.2	RIO Functions (Summary)	9
6.2.1	General functions	9
6.2.2	In/Out connectivity functions	10
<b>7</b>	<b>LIST OF the RIO LOGICAL NODES</b>	<b>11</b>
7.1	Logical Device Control: details of the Logical Nodes	13
7.1.1	Diagnostic – General state of the RIO	14
7.1.2	CID Management	15
7.1.3	Status of Remote (Wired) Inputs from the field	16
7.1.4	Control of Remote (Wired) Outputs towards the field	17
7.2	Virtual Input/Output Logical Device: Detail of LN	19
7.2.1	Virtual Input	19
7.2.2	Virtual Output	21
<b>8</b>	<b>ASPECTS OF DATA COMMUNICATION MODELED UNDER IEC61850</b>	<b>22</b>
<b>9</b>	<b>MISCELLANEOUS</b>	<b>24</b>
9.1	Clarification during the procurement process	24
9.2	ICD file revision control	24

## FIGURES

Figure 2	– RIO Logical Nodes	11
Figure 3	– Organization of the RIO's IEC61850 model	12
Figure 4	– IEC61850 Communication Streams and Services	22

## TABLES

Table 2	– Example of R values of the M/O column	12
Table 3	– Common Logical Node Class	12
Table 4	– LLN01 type	13
Table 5	– LNInstance: 1 – LPHD1 type	14
Table 6	– LNInstance: 1 - prefix: AnPa – CALH1 type	14

	GLOBAL STANDARD	Page 3 of 24
	Protection and control device for HV/MV substation – Communication profile (according to IEC 61850) for the MFP remote input/output module (MFP-RIO)	<b>GSTP104</b> Rev. 01 06/12/2018

<b>Table 7 – LNInstance: 1 - prefix: CIDMng – GGIO1 type.....</b>	<b>15</b>
<b>Table 8 – LNInstance: 1 - prefix: RIn01 GGIO2 type.....</b>	<b>16</b>
<b>Table 9 – LNInstance: 1 - prefix: RIn14GGIO2 type.....</b>	<b>16</b>
<b>Table 10 – LNInstance: 1 - prefix: ROut01GGIO3 type .....</b>	<b>17</b>
<b>Table 11 – LNInstance: 1 - prefix: ROut04GGIO3 type .....</b>	<b>18</b>
<b>Table 12 – LLN01 type.....</b>	<b>19</b>
<b>Table 13 – LNInstance: 1 – LPHD1 type .....</b>	<b>19</b>
<b>Table 14 – LNInstance: 1 - prefix: VIn01 – GGIO4 type.....</b>	<b>19</b>
<b>Table 15 – LNInstance: 1 - prefix: VIn32 – GGIO4 type.....</b>	<b>20</b>
<b>Table 16 – LNInstance: 1 - prefix: VOut – GGIO5 type.....</b>	<b>21</b>

	GLOBAL STANDARD	Page 4 of 24
	Protection and control device for HV/MV substation – Communication profile (according to IEC 61850) for the MFP remote input/output module (MFP-RIO)	<b>GSTP104</b> Rev. 01 06/12/2018

## 1 ACRONYSM

- a. **CID** Configured IED Description (XML file)
- b. **CP** HV/MV Distribution Substation
- c. **CS** MV/LV Distribution Substation
- d. **DA** Data Attribute
- e. **DO** Data Object
- f. **DS** Distribution Substation
- g. **GS** Enel Global Standard
- h. **HMI** Human-Machine Interface
- i. **HV** High Voltage
- j. **ICD** IED Capability Description (file)
- k. **IED** Intelligent Electronic Device
- l. **IEDp** Protection Relay or other IED requiring physical I/O extensions (for example the MFP)
- m. **LD** Logical Device
- n. **LN** Logical Node
- o. **LV** Low Voltage
- p. **MFP** Multifunctional feeder protection
- q. **MV** Medium Voltage
- r. **OdM** Circuit breaker / Switch
- s. **RIO** Remote I/O module of multifunctional feeder protection (MFP-RIO)
- t. **RTU** Remote Terminal Unit
- u. **SCD** Substation Configuration Description
- v. **SCL** Substation Configuration Language
- w. **SS** SubStation
- x. **TPT** RTU of a CP
- y. **TPT2020** TPT new generation with IEC61850 communication (Client and Server)

	GLOBAL STANDARD	Page 5 of 24
	Protection and control device for HV/MV substation – Communication profile (according to IEC 61850) for the MFP remote input/output module (MFP-RIO)	<b>GSTP104</b> Rev. 01 06/12/2018

## 2 LIST OF COMPONENTS, PRODUCT FAMILY OR SOLUTIONS TO WHICH THE GS APPLIES

The Multifunctional feeder protection (MFP) described in this GSTP10X series can be classified in several products provided in Table 1 in GSTP101.

	GLOBAL STANDARD	Page 6 of 24
	Protection and control device for HV/MV substation – Communication profile (according to IEC 61850) for the MFP remote input/output module (MFP-RIO)	<b>GSTP104</b> Rev. 01 06/12/2018

### 3 NORMATIVE REFERENCES AND BIBLIOGRAPHY

All the references in this GS are intended in the last revision or amendment.

#### 3.1 For all countries

IEC 61850-5	Communication networks and systems in substations - Part 5: Communication requirements for functions and device models
IEC 61850-7-3	Communication networks and systems for power utility automation - Part 7-3: Basic communication structure – Common data classes
IEC 61850-7-4	Communication networks and systems for power utility automation - Part 7-4: Basic communication structure - Compatible logical node classes and data object classes
IEC 61850-90-1	Communication networks and systems for power utility automation - Part 90-1: Use of IEC 61850 for the communication between substations
IEC 61850-6	Communication networks and systems for power utility automation - Part 6: Configuration description language for communication in electrical substations related to IEDs
IEC 61850-8-1	Communication networks and systems in substations - Part 8-1: Specific Communication Service Mapping (SCSM) - Mappings to MMS (ISO 9506-1 and ISO 9506-2) and to ISO/IEC 8802-3
IEEE 802.1Q	IEEE Standards for Local and Metropolitan Networks: Virtual Bridged Local Area Networks - Standard version suitable with the adopted protocols and/or IEC 61850 edition
IEC 61850-7-2	Communication networks and systems in substations - Part 7-2: Basic communication structure for substation and feeder equipment – Abstract communication service interface (ACSI)
RFC 2030	Simple Network Time Protocol (SNTP) V.4; RFC 1305 - Network Time Protocol Version 3 (NTPv3); RFC 5905 - Network Time Protocol Version 4 (NTPv4)
IEEE C37.2	Electrical Power System Device Function - Numbers and Contact Designation
GSCG002	Technical Conformity Assessment
GSTP10X series	Protection and control device for HV/MV substation – Multifunctional feeder protection (MFP)
GSTP901	Cybersecurity requirements for protection and control devices

	GLOBAL STANDARD	Page 7 of 24
	Protection and control device for HV/MV substation – Communication profile (according to IEC 61850) for the MFP remote input/output module (MFP-RIO)	<b>GSTP104</b> Rev. 01 06/12/2018

#### 4 REPLACED STANDARDS

Codification	Country	Title
DMI-9-00016	Italy	Requisiti costruttivi e funzionali del Pannello Multifunzione di Protezione e Controllo per Cabina Primaria

	GLOBAL STANDARD	Page 8 of 24
	Protection and control device for HV/MV substation – Communication profile (according to IEC 61850) for the MFP remote input/output module (MFP-RIO)	<b>GSTP104</b> Rev. 01 06/12/2018

## 5 APPLICATION FIELDS

This document standardizes the communication profile, according to the IEC 61850 standard, for the multifunctional feeder protection (MFP) remote Input/Output module (MFP-RIO), by according to GSTP102.

The RIO is an Intelligent Electronic Device (IED) used in Distribution Substation (DS) with the purpose of increasing the number of physical I/O of another IED (the MFP)

With reference to, the devices/system that will interoperate through this standard, a set of ENEL global devices is also mentioned, however some previous devices compliant to ENEL country standards may assure analogous level of interoperability.



	GLOBAL STANDARD	Page 9 of 24
	Protection and control device for HV/MV substation – Communication profile (according to IEC 61850) for the MFP remote input/output module (MFP-RIO)	<b>GSTP104</b> Rev. 01 06/12/2018

## 6 FEATURES OF THE RIO

### 6.1 Functional description

The RIO is an IED used to extend the number of physical I/O of an IED in the field (i.e. the electrical distribution grid); the MFP in this GST.

The RIO is typically located in a DS and is capable of communicating via:

- a. IEC 61850;
- b. Modbus TCP/IP;

Hereafter, only the first interface is specified.

The RIO implements a Server comprised of two Logical Devices (LDs) each consisting of the Logical Nodes (LNs) that model the data used by the RIO to accomplish its functions. The IED will be able to communicate via:

- c. LAN in the DS;
- d. dedicated/direct connections with the MFP.

The RIO will be able to implement LNs, protocol stacks and communication services as defined in the IEC 61850 standard (with particular reference to IEC61850-7-2, IEC61850-7-3, IEC61850-7-4, IEC61850-5, IEC61850-6, IEC61850-90-1, IEC61850-8-1) in order to support the features described in GSTP102, GSTP101 and summarized, for the reader's convenience, in the following section 6.2.

#### 6.1.1 Communication via LAN in the DS

The communication with the LAN in the DS is with the RTU (GSTR1XX series, TPT2020):

- a. Client of the HV/MV IEC61850 IEDs,
- b. Distributor of the CID files to the IEDs,
- c. Time server for the Synchronization (RFC2030);

Optionally, the communication via LAN in the DS may be with one or more clients during the development or special/temporary operation stages.

#### 6.1.2 Communication via dedicated/direct connections with the MFP

Dedicated/direct connections with the MFP whose physical connectivity to the field is extended by the RIO.

### 6.2 RIO Functions (Summary)

The functions of the RIO (refer to GSTP102), which must be supported by the IEC 61850 (data modelling and information exchange), are listed below.

#### 6.2.1 General functions

The general functions of the RIO are listed below:

- a. File Transfer (to send/receive the CID files, etc.);
- b. Diagnostic – General state of the RIO;
- c. IED Configuration

	GLOBAL STANDARD	Page 10 of 24
	Protection and control device for HV/MV substation – Communication profile (according to IEC 61850) for the MFP remote input/output module (MFP-RIO)	<b>GSTP104</b> Rev. 01 06/12/2018

### 6.2.2 In/Out connectivity functions

- a. 14 Remote Inputs from the field
- b. 4 Remote Outputs to the field

## 7 LIST OF THE RIO LOGICAL NODES

This chapter specifies the RIO data model according to the formal language of the IEC61850 standard.

The Physical Device (IED) consists of two Logical Devices (LDs) relevant to the functions performed by the RIO, in according to GSTP102.

Logical Device		LD Control					LD Virtual I/O
		Diagnostic – General state of the RIO (Alarm "AnPa")	CID Management	State of the [14] Remote (Wired) Inputs from the field	State of the [4] Remote (Wired) Outputs to the field	(32) Virtual Input	(16) Virtual Output
Functions							
Logical Nodes	CALH	X					
	GGIO		X	X	X	X	X

**Figure 1 – RIO Logical Nodes**

Figure 1 shows the association between a function (column) performed by the RIO and the dedicated logical nodes (rows) that define the data exchanged with the cooperating IEDs and the Client. LLN0 and LPHD are not mentioned as mandatory/default for the LD.

It is worth noting that only the functions requiring data and communication according to IEC 61850 are considered in this document.

When deemed necessary for specific project purposes the general classes proposed by the standard have been customized, while still remaining compliant, with the rules and constraints provided by the standard IEC 61850-7-4.

The resulting model, in terms of IED, LDs, LNs and their interrelationships is structured as shown in Figure 2.

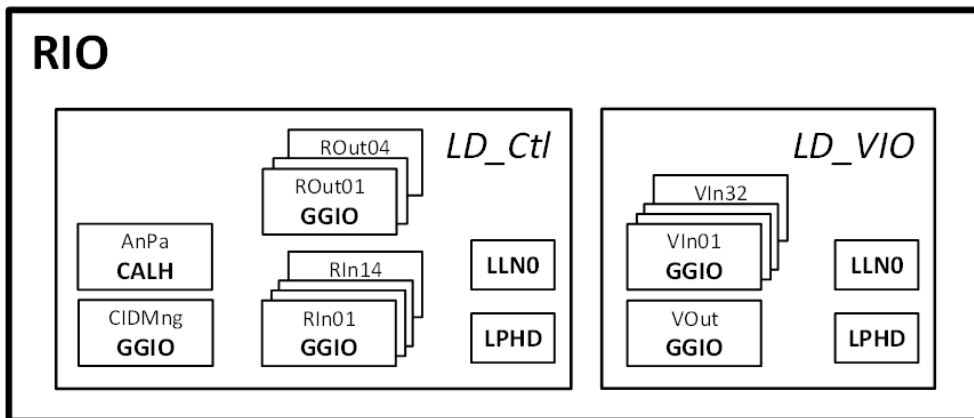

Figure 2 - Organization of the RIO's IEC61850 model

The following sections prescribe the data (DOs) included in the communication between the MFP and other IEDs with an exhaustive tabular description, refer to IEC 61850-7-4, for each selected LN.

Note that the typical values of the M/O column:

- a. M = mandatory,
  - b. O = optional,
  - c. C = conditional,
- are extended with the additional
- d. **R = required** (that means **mandatory to achieve the requirements of the ENEL project**, regardless of what is stated in the standard).

In Table 1 is shown an example extracted from LN MMXU.

...	...	...	...	...
Hz	MV	Frequency		O→R
PPV	DEL	Phase to phase voltages (VL1VL2, ...)		O→R
PhV	WYE	Phase to ground voltages (VL1ER, ...)		O
A	WYE	Phase currents (IL1, IL2, IL3)		O
W	WYE	Phase active power (P)		O
...	...	...		...

All of the logical nodes defined in IEC 61850-7-4 are derived from the **Common Logical Node Class**, they will inherit all its mandatory Data; for the optional data there are three possibilities for specialization:

- e. the piece of data is not inherited,
- f. the piece of data is inherited and left as optional,
- g. the piece of data is inherited and defined as mandatory;

Attribute Name	Attribute Type	Explanation	T	M/O
LNNName		Shall be inherited from Logical Node Class (IEC 61850-7-2)		
<b>Data</b>				
<b>Mandatory Logical Node Information (Shall be inherited by ALL LN but LPHD)</b>				

	GLOBAL STANDARD	Page 13 of 24
	Protection and control device for HV/MV substation – Communication profile (according to IEC 61850) for the MFP remote input/output module (MFP-RIO)	<b>GSTP104</b> Rev. 01 06/12/2018

Mod	INC	Mode		M
Beh	INS	Behaviour		M
Health	INS	Health		M
NamPlt	LPL	Name plate		M
<b>Optional Logical Node Information</b>				
Loc	SPS	Local operation		O
EEHealth	INS	External equipment health		O
EENam	DPL	External equipment name plate		O
OpCntRs	INC	Operation counter resettable		O
OpCnt	INS	Operation counter		O
OpTmh	INS	Operation time		O
<b>Data Sets (see IEC 61850-7-2)</b>				
Inherited and specialized from Logical Node class (see IEC 61850-7-2)				
<b>Control Blocks (see IEC 61850-7-2)</b>				
Inherited and specialized from Logical Node class (see IEC 61850-7-2)				
<b>Services (see IEC 61850-7-2)</b>				
Inherited and specialized from Logical Node class (see IEC 61850-7-2)				

Each table specifying a LN is followed, where necessary, by notes with details on the modelling;

As an aid to future proofing the IEDs it may be appropriate to seek the agreement of ENEL that additional information (with respect to GSTP102) could be modelled for specific LNs, thus also leveraging the scalability of the IEC-61850 standard;

Most LNs include a counter (resettable or not), which is considered an option by the standard, but is very useful for keeping track of the various states, alarms, parameters etc. depending on the functional requirements of the IED reported in the GSTP102 (e.g. number of Start/Operate of a protection, number of issued alarms, number of settings of particular parameters, etc.).

During the prototyping, special ENEL functions will be modelled using standard generic LNs such as CALH, GGIO, GAPC and applying the Extension Rules provided in the IEC 61850-7-4. In the final Data Model, as per the agreement with ENEL, these generic IEDs will be replaced with specific LNs with 'Name Space' dedicated to the ENEL project;

The activation/deactivation of a complete functionality will be achieved by controlling the DO Mod, that every specific LN inherits as Mandatory from the Common Logical Node Class;

The prefixes used in the model of a LN are, typically, acronyms/abbreviations of the underlying function (e.g. **R**Out**04** is Remote **O**utput number**04**).

## 7.1 Logical Device Control: details of the Logical Nodes

The Logical Device Control (LD\_Ctl) contains the Logical Nodes required to model the information used by the RIO to perform its tasks, according to GSTP102.

LLN0 is used to model the common parts of this Logical Device.

Table 3 – LLN01 type				
Attribute Name	Attribute Type	Explanation	T	M/O
LNNam		Shall be inherited from Logical Node Class (IEC 61850-7-2)		
<b>Data</b>				
<b>Common Logical Node Information</b>				

	GLOBAL STANDARD	Page 14 of 24
	Protection and control device for HV/MV substation – Communication profile (according to IEC 61850) for the MFP remote input/output module (MFP-RIO)	<b>GSTP104</b> Rev. 01 06/12/2018

		LN shall inherit all Mandatory Data from Common Logical Node Class		M
Loc	SPS	Local operation for complete logical device		O
OpTmh	INS	Operation Time		O
<b>Controls</b>				
Diag	SPC	Run Diagnostic		O
LEDRs	SPC	LED reset	T	O

LPHD models the common parts of the Physical Device that contains this Logical Device.

Table 4 – LNInstance: 1 – LPHD1 type				
Attribute Name	Attribute Type	Explanation	T	M/O
LNNName		Shall be inherited from Logical Node Class (IEC 61850-7-2)		
<b>Data</b>				
PhyNam	DPL	Physical device name plate		M
PhyHealth	INS	Physical device health		M
OutOv	SPS	Output communications buffer overflow		O
Proxy	SPS	Indicates if this LN is a proxy		M
InOv	SPS	Input communications buffer overflow		O
NumPwrUp	INS	Number of Power ups		O
WrmStr	INS	Number of Warm Starts		O
WacTrg	INS	Number of watchdog device resets detected		O
PwrUp	SPS	Power Up detected		O
PwrDn	SPS	Power Down detected		O
PwrSupAlm	SPS	External power supply alarm		O
RsStat	SPC	Reset device statistics	T	O

### 7.1.1 Diagnostic – General state of the RIO

The RIO implements an internal (HW and SW) diagnostic to monitor and notify, with a specific Alarm “AnPa”, its general state.

Table 5 – LNInstance: 1 - prefix: AnPa – CALH1 type				
Attribute Name	Attribute Type	Explanation	T	M/O
LNNName		Shall be inherited from Logical Node Class (IEC 61850-7-2)		
<b>Data</b>				
<b>Common Logical Node Information</b>				
		LN shall inherit all Mandatory Data from Common Logical Node Class		M
<b>Status Information</b>				
GrAlm	SPS	Group alarm		M
GrWrn	SPS	Group warning		O
AllmLstOv	SPS	Alarm list overflow		O

**NOTES:**

	GLOBAL STANDARD	Page 15 of 24
	Protection and control device for HV/MV substation – Communication profile (according to IEC 61850) for the MFP remote input/output module (MFP-RIO)	<b>GSTP104</b> Rev. 01 06/12/2018

**Status Information → GrAlm:** for sending the “AnPa” alarm in case of HW/SW faults of the equipment; it must be consistent with the available HMI (e.g. a LED) and/or log recorder of the IED:

- a. **0 = RIO OK**
- b. **1 = AnPA.**

RIO sends the AnPa signal via GOOSE to other IEDs in the DS (e.g. MFP used as MV protection) and is ready to Report it to a Client (e.g. RTU) too.

### 7.1.2 CID Management

The CID File, defined in GSTP102, used for the configuration of the IEC61850 communication, is transferred to/from the RIO via the File Transfer Service (FTP and/or IEC61850); typically, the peer in this procedure is the RTU (GSTR1XX series). Upon a successful file transfer, the IED parses the file and loads the configuration into a dedicated memory area (e.g. a stand-by memory bank). When this procedure completes (successfully or not), the RIO reports the status of the reconfiguration to the peer. In case of positive result, the RTU (GSTR1XX series) will request the RIO to switch to the new configuration with a confirmed procedure. File management on RIO depends on GSTP102.

Table 6 – LNInstance: 1 - prefix: CIDMng – GGIO1 type				
Attribute Name	Attribute Type	Explanation	T	M/O
LNName		Shall be inherited from Logical Node Class (IEC 61850-7-2)		
<b>Data</b>				
<b>Common Logical Node Information</b>				
		LN shall inherit all Mandatory Data from Common Logical Node Class		M
EEHealth	INS	External equipment health (external sensor)		O
EEName	DPL	External equipment name plate		O
Loc	SPS	Local operation		O
OpCntRs	INC	Resetable operation counter		R
<b>Measured values</b>				
AnIn	MV	Analogue input		O
<b>Controls</b>				
SPCSO	SPC	Single point controllable status output		R
DPCSO	DPC	Double point controllable status output		O
ISCSO	INC	Integer status controllable status output		O
<b>Status Information</b>				
IntIn	INS	Integer status input		R
Alm	SPS	General single alarm		O
Ind	SPS	General indication (binary input)		O

#### NOTES:

**Common Logical Node Information → OpCntRs (ready):** to count and store the number of reconfigurations

**Controls → SPCSO:** to handle the request to change to the new configuration (Boolean = 1). The request is confirmed; at the end of the procedure, the RIO changes the value to 0

**Status Information → IntIn:** for sending the CIDReconfig notification, according to the outcome of the reconfiguration procedure via a new CID file:

- a. 1 = OK,

	GLOBAL STANDARD	Page 16 of 24
	Protection and control device for HV/MV substation – Communication profile (according to IEC 61850) for the MFP remote input/output module (MFP-RIO)	<b>GSTP104</b> Rev. 01 06/12/2018

- b. 2 = abnormal/unexpected reconfiguration via new CID,
- c. 3 = abnormal/unexpected status after reboot with new reconfiguration,

RIO is designed to carry out the reconfigurations by means of Client/Server communication (Control and Reporting services) with a Client (e.g. TPT2020).

### 7.1.3 Status of Remote (Wired) Inputs from the field

The RIO according to GSTP102 extends the number of Digital Inputs from the field of an IEDp; the status of these inputs is modelled with a set of Booleans whose value is transferred to the IEDp. The semantic of each Input is out of the scope of the RIO; it's up to the IEDp to assign a meaning to the status of each Boolean received via GOOSE (subscribed) from the RIO.

The RIO acquires and notifies the status of 14 Inputs from the field.

The following LNs model the Remote Input status.

Table 7 – LNInstance: 1 - prefix: RIn01 GGIO2 type				
Attribute Name	Attribute Type	Explanation	T	M/O
LNNName		Shall be inherited from Logical Node Class (IEC 61850-7-2)		
<b>Data</b>				
<b>Common Logical Node Information</b>				
		LN shall inherit all Mandatory Data from Common Logical Node Class		M
EEHealth	INS	External equipment health (external sensor)		O
EENName	DPL	External equipment name plate		O
Loc	SPS	Local operation		O
OpCntRs	INC	Resetable operation counter		R
<b>Measured values</b>				
AnIn	MV	Analogue input		O
<b>Controls</b>				
SPCSO	SPC	Single point controllable status output		O
DPCSO	DPC	Double point controllable status output		O
ISCSO	INC	Integer status controllable status output		O
<b>Status Information</b>				
IntIn	INS	Integer status input		O
Alm	SPS	General single alarm		O
Ind	SPS	General indication (binary input)		R

### LNInstance: 1 - prefix: RIn02...RIn13

Same LN Type.

Table 8 – LNInstance: 1 - prefix: RIn14GGIO2 type				
Attribute Name	Attribute Type	Explanation	T	M/O
LNNName		Shall be inherited from Logical Node Class (IEC 61850-7-2)		
<b>Data</b>				
<b>Common Logical Node Information</b>				
		LN shall inherit all Mandatory Data from Common Logical Node Class		M
EEHealth	INS	External equipment health (external sensor)		O
EENName	DPL	External equipment name plate		O



	GLOBAL STANDARD	Page 17 of 24
	Protection and control device for HV/MV substation – Communication profile (according to IEC 61850) for the MFP remote input/output module (MFP-RIO)	<b>GSTP104</b> Rev. 01 06/12/2018

Loc	SPS	Local operation		O
OpCntRs	INC	Resetable operation counter		R
<b>Measured values</b>				
AnIn	MV	Analogue input		O
<b>Controls</b>				
SPCSO	SPC	Single point controllable status output		O
DPCSO	DPC	Double point controllable status output		O
ISCSO	INC	Integer status controllable status output		O
<b>Status Information</b>				
IntIn	INS	Integer status input		O
Alm	SPS	General single alarm		O
Ind	SPS	General indication (binary input)		R

**NOTES:**

**Common Logical Node Information** → **OpCntRs** (ready): to count and store the number of events occurred

**Status Information** → **Ind**: for notifying the status of the Remote Input<sub>j</sub> (j = 1..14) from the field:

- a. 0 = opened contact / Disabled input
- b. 1 = closed contact / Activated input.

**7.1.4 Control of Remote (Wired) Outputs towards the field**

The RIO according to GSTP102 extends the number of Digital Outputs to the field of an IEDp; the status of these Outputs is modelled with a set of Booleans whose value is controlled by the IEDp. The semantic of each Output is out of the scope of the RIO; it's up to the IEDp to assign a meaning to the status of each Boolean transmitted via GOOSE (published) to the RIO.

On behalf of the IEDp the RIO controls (and notifies back for confirmation to the IEDp) the status of four Outputs to the field.

The following tables define the LN used to manage the outputs.

Table 9 – LNInstance: 1 - prefix: ROut01GGIO3 type				
Attribute Name	Attribute Type	Explanation	T	M/O
LNName		Shall be inherited from Logical Node Class (IEC 61850-7-2)		
<b>Data</b>				
<b>Common Logical Node Information</b>				
		LN shall inherit all Mandatory Data from Common Logical Node Class		M
EEHealth	INS	External equipment health (external sensor)		O
EEName	DPL	External equipment name plate		O
Loc	SPS	Local operation		O
OpCntRs	INC	Resetable operation counter		R
<b>Measured values</b>				
AnIn	MV	Analogue input		O
<b>Controls</b>				
SPCSO	SPC	Single point controllable status output		R
DPCSO	DPC	Double point controllable status output		O

	GLOBAL STANDARD	Page 18 of 24
	Protection and control device for HV/MV substation – Communication profile (according to IEC 61850) for the MFP remote input/output module (MFP-RIO)	<b>GSTP104</b> Rev. 01 06/12/2018

ISCSO	INC	Integer status controllable status output		O
<b>Status Information</b>				
IntIn	INS	Integer status input		O
Alm	SPS	General single alarm		O
Ind	SPS	General indication (binary input)		R

**LNInstance: 1 - prefix: ROut02... ROut03**

Same LN Type.

Table 10 – LNInstance: 1 - prefix: ROut04GGIO3 type				
Attribute Name	Attribute Type	Explanation	T	M/O
LNNName		Shall be inherited from Logical Node Class (IEC 61850-7-2)		
<b>Data</b>				
<b>Common Logical Node Information</b>				
		LN shall inherit all Mandatory Data from Common Logical Node Class		M
EEHealth	INS	External equipment health (external sensor)		O
EENName	DPL	External equipment name plate		O
Loc	SPS	Local operation		O
OpCntRs	INC	Resetable operation counter		R
<b>Measured values</b>				
AnIn	MV	Analogue input		O
<b>Controls</b>				
SPCSO	SPC	Single point controllable status output		R
DPCSO	DPC	Double point controllable status output		O
ISCSO	INC	Integer status controllable status output		O
<b>Status Information</b>				
IntIn	INS	Integer status input		O
Alm	SPS	General single alarm		O
Ind	SPS	General indication (binary input)		R

**NOTES:**

**Common Logical Node Information → OpCntRs** (ready): to count and store the number of commands received

**Controls → SPCSO:** to change the state of the Remote Output<sub>j</sub> (j = 1..4) to the field according to the main IED's request:

- a. 0 = open contact / Disable the output
- b. 1 = close contact / Activate the output

**Status Information → Ind:** for notifying the status of the Remote Output<sub>j</sub> (j = 1..4) to the field:

- c. 0 = opened contact / Disabled output
- d. 1 = closed contact / Activated output.

The RIO is ready to subscribe the GOOSE published by other IEDs (e.g. MFP) in the four instances of this LN and is ready to send back the status of the Output signal j (j = 1..4) via GOOSE.

	GLOBAL STANDARD	Page 19 of 24
	Protection and control device for HV/MV substation – Communication profile (according to IEC 61850) for the MFP remote input/output module (MFP-RIO)	<b>GSTP104</b> Rev. 01 06/12/2018

## 7.2 Virtual Input/Output Logical Device: Detail of LN

The Virtual Input/Output Logical Device (LD\_VIO) contains all the LNs needed to model experimental inputs and outputs ready for any future use/development, and in particular is capable of handling the (optional) PLC logics inside the RIO.

Table 11 – LLN01 type				
Attribute Name	Attribute Type	Explanation	T	M/O
LNNName		Shall be inherited from Logical Node Class (IEC 61850-7-2)		
<b>Data</b>				
<b>Common Logical Node Information</b>				
		LN shall inherit all Mandatory Data from Common Logical Node Class		M
Loc	SPS	Local operation for complete logical device		O
OpTmh	INS	Operation Time		O
<b>Controls</b>				
Diag	SPC	Run Diagnostic		O
LEDRs	SPC	LED reset	T	O

Table 12 – LNInstance: 1 – LPHD1 type				
Attribute Name	Attribute Type	Explanation	T	M/O
LNNName		Shall be inherited from Logical Node Class (IEC 61850-7-2)		
<b>Data</b>				
PhyNam	DPL	Physical device name plate		M
PhyHealth	INS	Physical device health		M
OutOv	SPS	Output communications buffer overflow		O
Proxy	SPS	Indicates if this LN is a proxy		M
InOv	SPS	Input communications buffer overflow		O
NumPwrUp	INS	Number of Power ups		O
WrmStr	INS	Number of Warm Starts		O
WacTrg	INS	Number of watchdog device resets detected		O
PwrUp	SPS	Power Up detected		O
PwrDn	SPS	Power Down detected		O
PwrSupAlm	SPS	External power supply alarm		O
RsStat	SPC	Reset device statistics	T	O

### 7.2.1 Virtual Input

Table 13 – LNInstance: 1 - prefix: VIn01 – GGIO4 type				
Attribute Name	Attribute Type	Explanation	T	M/O
LNNName		Shall be inherited from Logical Node Class (IEC 61850-7-2)		
<b>Data</b>				
<b>Common Logical Node Information</b>				
		LN shall inherit all Mandatory Data from Common Logical Node Class		M
EEHealth	INS	External equipment health (external sensor)		O

	GLOBAL STANDARD	Page 20 of 24
	Protection and control device for HV/MV substation – Communication profile (according to IEC 61850) for the MFP remote input/output module (MFP-RIO)	<b>GSTP104</b> Rev. 01 06/12/2018

EEName	DPL	External equipment name plate	O
Loc	SPS	Local operation	O
OpCntRs	INC	Resetable operation counter	R
<b>Measured values</b>			
AnIn	MV	Analogue input	O
<b>Controls</b>			
SPCSO	SPC	Single point controllable status output	R
DPCSO	DPC	Double point controllable status output	O
ISCSO	INC	Integer status controllable status output	O
<b>Status Information</b>			
IntIn	INS	Integer status input	O
Alm	SPS	General single alarm	R
Ind	SPS	General indication (binary input)	O

**LNInstance: 1 - prefix: VIn02..VIn31**

Same LN Type.

Table 14 – LNInstance: 1 - prefix: VIn32 – GGIO4 type				
Attribute Name	Attribute Type	Explanation	T	M/O
LNNName		Shall be inherited from Logical Node Class (IEC 61850-7-2)		
<b>Data</b>				
<b>Common Logical Node Information</b>				
		LN shall inherit all Mandatory Data from Common Logical Node Class		M
EEHealth	INS	External equipment health (external sensor)		O
EEName	DPL	External equipment name plate		O
Loc	SPS	Local operation		O
OpCntRs	INC	Resetable operation counter		R
<b>Measured values</b>				
AnIn	MV	Analogue input		O
<b>Controls</b>				
SPCSO	SPC	Single point controllable status output		R
DPCSO	DPC	Double point controllable status output		O
ISCSO	INC	Integer status controllable status output		O
<b>Status Information</b>				
IntIn	INS	Integer status input		O
Alm	SPS	General single alarm		R
Ind	SPS	General indication (binary input)		O

**NOTES:**

**Common Logical Node Information** → **OpCntRs**: to count and store the number of State variations

**Controls** → **SPCSO**: available/ready Input n (n = 1..32)

**Controls** → **Alm**: available/ready signalling n (n = 1..32).

	GLOBAL STANDARD	Page 21 of 24
	Protection and control device for HV/MV substation – Communication profile (according to IEC 61850) for the MFP remote input/output module (MFP-RIO)	<b>GSTP104</b> Rev. 01 06/12/2018

## 7.2.2 Virtual Output

Table 15 – LNInstance: 1 - prefix: VOut – GGIO5 type				
Attribute Name	Attribute Type	Explanation	T	M/O
LNNName		Shall be inherited from Logical Node Class (IEC 61850-7-2)		
<b>Data</b>				
<b>Common Logical Node Information</b>				
		LN shall inherit all Mandatory Data from Common Logical Node Class		M
EEHealth	INS	External equipment health (external sensor)		O
EEName	DPL	External equipment name plate		O
Loc	SPS	Local operation		O
OpCntRs	INC	Resetable operation counter		O
<b>Measured values</b>				
AnIn	MV	Analogue input		O
<b>Controls</b>				
SPCSO	SPC	Single point controllable status output		O
DPCSO	DPC	Double point controllable status output		O
ISCSO	INC	Integer status controllable status output		O
<b>Status Information</b>				
IntIn	INS	Integer status input		O
Alm	SPS	General single alarm		O
Ind1	SPS	General indication (binary input)		R
Ind2	SPS	General indication (binary input)		R
Ind3	SPS	General indication (binary input)		R
Ind4	SPS	General indication (binary input)		R
Ind5	SPS	General indication (binary input)		R
Ind6	SPS	General indication (binary input)		R
Ind7	SPS	General indication (binary input)		R
Ind8	SPS	General indication (binary input)		R
Ind9	SPS	General indication (binary input)		R
Ind10	SPS	General indication (binary input)		R
Ind11	SPS	General indication (binary input)		R
Ind12	SPS	General indication (binary input)		R
Ind13	SPS	General indication (binary input)		R
Ind14	SPS	General indication (binary input)		R
Ind15	SPS	General indication (binary input)		R
Ind16	SPS	General indication (binary input)		R

### NOTES:

**Controls**→ Ind1: available/ready Output 1 (Optional, to notify the results of the internal PLC logics)

**Controls**→ Ind2: available/ready Output 2 (Optional, to notify the results of the internal PLC logics)

**Controls**→ Ind3: available/ready Output 3 (Optional, to notify the results of the internal PLC logics)

**Controls**→ Ind4: available/ready Output 4 (Optional, to notify the results of the internal PLC logics)

**Controls**→ Ind5: available/ready Output 5 (Optional, to notify the results of the internal PLC logics)

	GLOBAL STANDARD	Page 22 of 24
	Protection and control device for HV/MV substation – Communication profile (according to IEC 61850) for the MFP remote input/output module (MFP-RIO)	<b>GSTP104</b> Rev. 01 06/12/2018

- Controls**→ **Ind6**: available/ready Output 6 (Optional, to notify the results of the internal PLC logics)
- Controls**→ **Ind7**: available/ready Output 7 (Optional, to notify the results of the internal PLC logics)
- Controls**→ **Ind8**: available/ready Output 8 (Optional, to notify the results of the internal PLC logics)
- Controls**→ **Ind9**: available/ready Output 9 (Optional, to notify the results of the internal PLC logics)
- Controls**→ **Ind10**: available/ready Output 10 (Optional, to notify the results of the internal PLC logics)
- Controls**→ **Ind11**: available/ready Output 11 (Optional, to notify the results of the internal PLC logics)
- Controls**→ **Ind12**: available/ready Output 12 (Optional, to notify the results of the internal PLC logics)
- Controls**→ **Ind13**: available/ready Output 13 (Optional, to notify the results of the internal PLC logics)
- Controls**→ **Ind14**: available/ready Output 14 (Optional, to notify the results of the internal PLC logics)
- Controls**→ **Ind15**: available/ready Output 15 (Optional, to notify the results of the internal PLC logics)
- Controls**→ **Ind16**: available/ready Output 16 (Optional, to notify the results of the internal PLC logics).

## 8 ASPECTS OF DATA COMMUNICATION MODELED UNDER IEC61850

Figure 3 describes the set of protocol stacks, ref. IEEE 802.1Q, and communication services (ref. IEC61850-5) defined in the IEC61850 standard and used to communicate with the IEDs of the DS.

In Figure 3 KA Communication is used for “keep alive” communication.

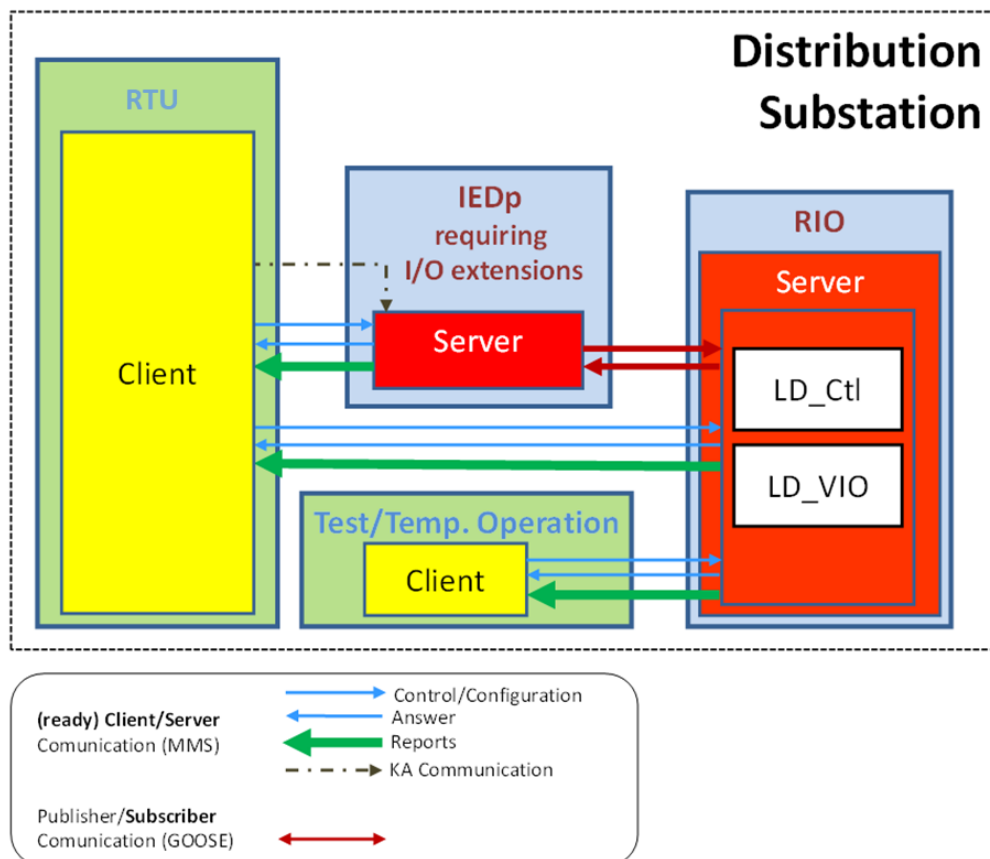



Figure 3 – IEC61850 Communication Streams and Services

	GLOBAL STANDARD	Page 23 of 24
	Protection and control device for HV/MV substation – Communication profile (according to IEC 61850) for the MFP remote input/output module (MFP-RIO)	<b>GSTP104</b> Rev. 01 06/12/2018

The RIO uses Client/Server messaging to communicate with the RTU (GSTR1XX series) in the DS, according to the following architecture and protocols IEEE.802.1Q:

- a. 7 OSI Layers,
- b. ACSI via MMS via TCP/IP via ISO/IEC 8802-3,
- c. Unicast

for commands/controls, configurations, periodic spontaneous reporting or events.

The IED will also interoperate with other Servers in the DS for bay/field automation via GOOSE, ref. to IEEE.802.1Q:

- d. 3 OSI Layers,
- e. GOOSE via ISO/IEC 8802-3 via IEEE 802.1Q (Virtual LAN),
- f. Multicast.

The spreadsheet file will be provided by ENEL during the procurement process (ref. Par.9.1)

	GLOBAL STANDARD	Page 24 of 24
	Protection and control device for HV/MV substation – Communication profile (according to IEC 61850) for the MFP remote input/output module (MFP-RIO)	<b>GSTP104</b> Rev. 01 06/12/2018

## 9 MISCELLANEOUS

This chapter include further requirements, recommendations and additional information.

### 9.1 Clarification during the procuremen process

By summarizing, during the procurement process the following clarification will be provided to the supplier:

- a. The spreadsheet file that modelled the input/output required in GSTP102 according to IEC 61850 as described in chapters 7 and 8;
- b. The ICD file that implement the formal description of the IED in chapters 7 and 8.

### 9.2 ICD file revision control

Owing to the changes affecting the information model or the communication of the IED, the following rules are adopted to ensure that the version numbering clearly identifies each variation or iteration of the ICD file.

```
<Header id = "IEDxxx ENEL" version = "v" revision = "rrr" toolID = "" nameStructure = "IEDName" />
```

- a. **version** is an integer increased by one unit for major releases (e.g. during the prototyping it will be 1, in operation it will be 2 or more),
- b. **revision** is an integer increased by one unit for minor releases due to some new feature (affecting the Data Model or the Communication) or bug fix. It is reset to zero when the version changes.

```
<ReportControl ... confRev="c" dataSet="xxx".../>
```

```
<GSEControl ... confRev="c" dataSet="xxx".../>
```

The **confRev**, by IEC 61850 standard, is an integer starting from "1" that increments

- c. when the referenced dataSet is changed ,ref IEC 61850-5,
- d. when the Report or the GOOSE control block itself is modified IEC 61850-6,
- e. the counter is never reset.

For example, the attached ICD file may have

Header

- f. **version** = "2" (for operation)
- g. **revision** = "0" (no minor revisions since the last major version)
- h. <GSEControl name = "gcb\_TDLP"
- i. **confRev** = "3" (due to modified Data Set or Control Block since the prototyping).