



**Application Areas**

Perimeter: *Global*

Staff Function: -

Service Function: -

Business Line: *Infrastructure & Networks*

---

## CONTENTS

1	DOCUMENT AIMS AND APPLICATION AREA .....	3
1.1	RELATED DOCUMENTS TO BE IMPLEMENTED AT COUNTRY LEVEL.....	3
2	DOCUMENT VERSION MANAGEMENT .....	3
3	UNITS IN CHARGE OF THE DOCUMENT .....	4
4	REFERENCES, LAWS AND STANDARDS.....	4
5	ORGANIZATIONAL PROCESS POSITION IN THE PROCESS TAXONOMY .....	7
6	DEFINITIONS AND ACRONYMS .....	7
7	DESCRIPTION.....	7
7.1	Components list.....	7
7.2	SERVICE CONDITIONS .....	8
7.2.1	General service conditions .....	8
7.2.2	Specific service conditions.....	8
7.3	TECHNICAL CHARACTERISTICS .....	9
7.4	CONSTRUCTION CHARACTERISTICS .....	10
7.4.1	General characteristics .....	10
7.4.2	DS/ES Mechanical interlocking .....	10
7.4.3	Insulators .....	10
7.4.4	HV terminals .....	10
7.4.5	Grounding .....	11
7.4.6	Control and Operating device Box(es) .....	11
7.4.7	Protective treatments.....	14
7.4.8	Dimensional characteristics .....	15
7.4.9	Support .....	15
7.4.10	Nameplates .....	15
7.5	FUNCTIONAL CHARACTERISTICS .....	15
7.5.1	Common requirements .....	15
7.5.2	e-distribucion and E-Distributie functional characteristics .....	17
7.5.3	e-distribuzione functional characteristics.....	17
7.5.4	Latam functional characteristics .....	21
7.6	TESTING .....	22
7.6.1	General information .....	22



**Application Areas**

Perimeter: *Global*

Staff Function: -

Service Function: -

Business Line: *Infrastructure & Networks*

---

7.6.2	Type tests .....	22
7.6.3	Routine Tests.....	24
7.6.4	Commissioning tests.....	25
7.7	SUPPLY REQUIREMENTS .....	25
7.7.1	Tender's technical documentation.....	25
7.7.2	Conformity assessment .....	25
7.7.3	Packaging, transport, storage and installation/testing.....	25
ANNEX A	– ELECTRICAL SCHEMES .....	27
ANNEX B	– DIMENSIONAL DRAWINGS.....	41
ANNEX C	– TENDER'S TECHNICAL DOCUMENTATION.....	47
ANNEX D	– COMPONENT LIST .....	48

THE HEAD OF NETWORK COMPONENTS  
**Maurizio Mazzotti**

**Application Areas**

 Perimeter: *Global*

Staff Function: -

Service Function: -

 Business Line: *Infrastructure & Networks*

## 1 DOCUMENT AIMS AND APPLICATION AREA

The scope of this document is to provide technical requirements for the supply of HV disconnectors (hereinafter DS) and earthing switches (hereinafter ES) with rated voltage from 72.5 kV to 245 kV in the Enel Group Distribution companies, listed below:

Country	Distribution Company
Argentina	Edesur
Brazil	Enel Distribuição Rio Enel Distribuição Ceará Enel Distribuição Goiás Enel Enel Distribuição São Paulo
Chile	Enel Distribución Chile
Colombia	Codensa
España	e-distribución
Italy	e-distribuzione
Peru	Enel Distribución Perú
Romania	Enel Distributie Banat Enel Distributie Dobrogea Enel Distributie Muntenia

Note: the indication "Latam" refers to the Enel Group Distribution companies in South America.

Some requirements are applicable only to one or more companies, therefore, depending on the destination of the surge arresters, the supplied equipment shall comply these specific requirements.

### 1.1 RELATED DOCUMENTS TO BE IMPLEMENTED AT COUNTRY LEVEL

This document applies to both Enel Global Infrastructure and Networks Srl Company and to Infrastructure and Networks Business Line perimeter, when each Company does not have to issue further documents.

## 2 DOCUMENT VERSION MANAGEMENT

Version	Date	Main changes description
00	30/09/2013	First emission
01	17/01/2014	New Type Codes in Component List of Enel Distribución Chile and Ampla Renumbered the Type Code for all items in Component List Editorial corrections Raised a.c. max absorbed power (VA)
02	30/05/2014	Added new columns in table in chapter 5 Introduction of alternative materials in nameplates (7.4.10) Added a new requirement in 7.5.1.1 for centre-break DSs Corrected 7.5.3.2.b), Closing block, b)

**Application Areas**

 Perimeter: *Global*

Staff Function: -

Service Function: -

 Business Line: *Infrastructure & Networks*

		Added information about low voltage components in 7.5.3.4 Updated paragraph 7.5.4.1 Deleted sentence about measuring of resistance of earthing switch in 7.6.2.6 Modified requirement in 9.3 Updated fig. A.2.6 Annex A3: added electric schemes for Ampla and Edesur Added a note in the 2 <sup>nd</sup> figure of Annex B.2 Added a sentence at the beginning of Annex B.4 Added 2 notes in Annex D and the codes GSCH3/506..509 (EDELNOR) Added in 3.2.2. a new specific standard for Spain Added 9.3.1 Specific requirement for e-distribucion
03	17/04/2018	Introduction of Enel Goiás Exclusion of ceramic insulators New codes in Annex D New electric schemes for Italy Codes, description and electrical characteristics for Romania (05/11/2019)
04	08/04/2020	Introduction of Enel Sao Paulo Changes in 8.3 Routine Tests Clarification in 6.3. only polymeric insulators are accepted Modified Annex D Spain, Chile, Codensa codes 3.2.1 Add IEC polymeric insulators Remove IEC about ceramic insulators 8.2.17 Tests on insulators IEC
04	17/09/2021	Errors in table 7.3 Change in 7.6.3 Routine tests Codes E4E Brasil
04	24/11/2021	Format and editorial changes Introduction of new codes for Goiás and new codes 52kV for Spain

### 3 UNITS IN CHARGE OF THE DOCUMENT

Responsible for drawing up the document:

- Global Infrastructure and Networks: Engineering and Construction / Components and Devices Design / Network Components.

Responsible for authorizing the document:

- Global Infrastructure and Networks: Head of Network Components unit
- Global Infrastructure and Networks: Head of Quality unit.

### 4 REFERENCES, LAWS AND STANDARDS

- Code of Ethics of Enel Group;

**Application Areas**Perimeter: *Global*

Staff Function: -

Service Function: -

Business Line: *Infrastructure & Networks*

- 
- Enel Human Right Policy;
  - The Enel Group Zero Tolerance of Corruption (ZTC) Plan;
  - Organization and management model as per Legislative Decree No. 231/2001;
  - RACI Handbook Infrastructure and Networks no. 06;
  - Enel Global Compliance Program (EGCP);
  - Integrated Policy of Quality, Health and Safety, Environment and anti-Bribery;
  - ISO 9001:2015 - Quality Management System - Requirements;
  - ISO 14001:2015 - Environmental Management System - Requirements and user guide;
  - ISO 45001:2018 - Occupational Health and Safety Management System - Requirements and user guide;
  - ISO 50001:2018 - Energy management systems - Requirements with guidance for use;
  - ISO 37001:2016 - Anti-bribery Management System - Requirements with guidance for use.
  - IEC 62271-1 - High voltage switchgear and controlgear. Part 1: Common specifications.
  - IEC 62271-102 - Alternating current disconnectors and earthing switches
  - IEC 60273 - Characteristic of indoor and outdoor post insulators for systems with nominal voltages greater than 1000 V
  - IEC 62231 - Composite station post insulators for substations with a.c. voltages greater than 1 000 V up to 245 kV - Definitions, test methods and acceptance criteria
  - IEC 60507 - Artificial pollution tests on high-voltage insulators to be used on a.c. systems
  - IEC/TR 62271-300 - High-voltage switchgear and controlgear – Part 300: Seismic qualification of alternating current circuit breakers
  - IEC/TR 62271-301 - High-voltage switchgear and controlgear – Part 301: Dimensional standardization of high-voltage terminals
  - IEC 60073 - Basic and safety principles for man-machine interface, marking and identification – Coding principles for indicators and actuators
  - IEC 60447 - Basic and safety principles for man-machine interface, marking and identification - Actuating principles
  - IEC/TS 60815-1 - Selection and dimensioning of high-voltage insulators intended for use in polluted conditions – Part 1: Definitions, information and general principles
  - IEC/TS 60815-3 - Selection and dimensioning of high-voltage insulators intended for use in polluted conditions – Part 3: Polymer insulators for a.c. systems
  - IEC 60332-3-24 - Tests on electric and optical fibre cables under fire conditions – Part 3-24: Test for vertical flame spread of vertically-mounted bunched wires or cables - Category C
  - ISO 1461 - Hot dip galvanized coatings on fabricated iron and steel articles- Specifications and test methods
  - EN 50575 Power, control and communication cables - Cables for general applications in construction works subject to reaction to fire requirements

**Application Areas**Perimeter: *Global*

Staff Function: -

Service Function: -

Business Line: *Infrastructure & Networks*

- EN 1005-3:2002 - Safety of machinery. Human physical performance Recommended force limits for machinery operation
- IEC 61462 - Composite hollow insulators - Pressurized and unpressurized insulators for use in electrical equipment with rated voltage greater than 1 000 V - Definitions, test methods, acceptance criteria and design recommendations
- IEC 60587 - Electrical insulating materials used under severe ambient conditions - Test methods for evaluating resistance to tracking and erosion
- IEC TS 62073 - Guidance on the measurement of hydrophobicity of insulator surfaces
- IEC TS 62039 - Selection guide for polymeric materials for outdoor use under HV stress
- Specific for e-distribución and Spain:
  - Real Decreto Riesgo Eléctrico 614/2001 sobre disposiciones mínimas para la protección de la salud y seguridad de los trabajadores frente al riesgo eléctrico
  - Reglamento sobre condiciones técnicas y garantías de seguridad en instalaciones eléctricas de alta tensión, Real Decreto 337/2014.
  - IEC 60332 Métodos de ensayo para cables eléctricos y cables de fibra óptica sometidos a condiciones de fuego. Parte 1-1: Ensayo de resistencia a la propagación vertical de la llama para un conductor individual aislado o cable.
  - IEC 60754-1 and 60754-2 Ensayo de los gases desprendidos durante la combustión de materiales procedentes de los cables.
  - Reglamento sobre condiciones técnicas y garantías de seguridad en instalaciones eléctricas de alta tensión, Real Decreto 337/2014.
  - NMC001: Procedimiento para el conexionado de armarios cuadros y paneles
  - NNC007: Cables de control multipolares
  - NNM001 – Normas de operación definiciones
- Specific for E-Distribuzione and Italy:
  - CEI 20-22/2 – Prove di incendio su cavi elettrici – Parte 2: Prova di non propagazione dell'incendio
  - ENEL operative note PVR006 (bar code)
  - LM 1023 (double cable 245 kV clamp)
  - LM 1026 (single cable 245 kV clamp)
- Specific for Brasil:
  - NR-10 - SEGURANÇA EM INSTALAÇÕES E SERVIÇOS EM ELETRICIDADE
- Specific for Colombia:
  - Resolución 9 0708 de Agosto 30 de 2013 con sus ajustes – REGLAMENTO TÉCNICO DE INSTALACIONES ELÉCTRICAS RETIE.
  - NTC 2050 Código Eléctrico Colombiano
- Specific for Chile:

**Application Areas**

Perimeter: *Global*

Staff Function: -

Service Function: -

Business Line: *Infrastructure & Networks*

- ETGI-1020 - Especificaciones técnicas generales - Requisitos de diseño sísmico para equipo eléctrico
- Specific for e-Distributie and Romania:
  - CEI 20-22/2 – Prove di incendio su cavi elettrici – Parte 2: Prova di non propagazione dell'incendio
  - LS6016 Specifica Tecnica Enel – Sostegni per sezionatori tripolari 132 – 150 kV

**Notes:**

- The above listed reference documents shall be intended in the in-force edition at the contract date (amendment included).
- For Latin America destinations the reference standard are the IEC/ISO, whilst for Europe destinations the reference standard are the correspondent European standards (EN).

**5 ORGANIZATIONAL PROCESS POSITION IN THE PROCESS TAXONOMY**

Value Chain/Process Area: Networks Management

Macro Process: Materials management

Process: Network components standardization

**6 DEFINITIONS AND ACRONYMS**

Acronym and Key words	Description
<b>Technical Conformity Assessment (TCA)</b>	A “conformity assessment” <sup>1</sup> with respect to “specified requirements” <sup>2</sup> consists in functional, dimensional, constructional and test characteristics required for a product (or a series of products) and quoted in technical specifications and quality requirements issued by Enel Group distribution companies. This also includes the verification of conformity with respect to local applicable regulation and laws and possession of relevant requested certifications
<b>Type A documentation</b>	Not confidential documents used for product manufacturing and management from which it is possible to verify the product conformity to all technical specification requirements, directly or indirectly

**7 DESCRIPTION**

**7.1 Components list**

The HV DS and, if required, ES are composed by two or three columns per each pole.

<sup>1</sup> Definition 2.1 of ISO/IEC 17000

<sup>2</sup> Definition 3.1 of ISO/IEC 17000

**Application Areas**

 Perimeter: *Global*

Staff Function: -

Service Function: -

 Business Line: *Infrastructure & Networks*

Two main typologies are provided:

- Three columns per each pole (double-break)
- Two columns per each pole (centre-break)

The complete list of the equipment with their main characteristics is in Annex D (Common List of HV DS/ESs).

Other types occasionally could be required in special situations. The requirements will be indicated properly and opportunely.

## 7.2 SERVICE CONDITIONS

### 7.2.1 General service conditions

The reference service conditions are the outdoor normal service conditions of IEC 62271-1 (par. 2.1.2), with the further indications in Annex D.

### 7.2.2 Specific service conditions

#### 7.2.2.1 Colombia

The reference altitude is 2.600 m<sup>3</sup>.

#### 7.2.2.2 Seismic qualification level

Enel Distribución Chile	ETGI-1020
Enel Codensa	AF5 (IEC/TR 62271-300)
Enel Distribución Perú	AF5 (IEC/TR 62271-300)
E-Distributie	AF5 (IEC/TR 62271-300)
e-distribuzione	AF5 (IEC/TR 62271-300)

<sup>3</sup> For Colombia the rated insulation levels in chapter 5 already consider the altitude effect on the external insulation, therefore the correction in clause 2.1.1 of IEC 62271-1 is not required. On the contrary are confirmed the precautions to be taken for low-voltage auxiliary and control equipments.



**Application Areas**

 Perimeter: *Global*

Staff Function: -

Service Function: -

 Business Line: *Infrastructure & Networks*
**7.3 TECHNICAL CHARACTERISTICS**

DISCONNECTOR/EARTHING SWITCH												
Rated voltage $U_r$ (kV)		72,5		123	145			170	245			
Rated short-time withstand current $I_k$ (kA)		25/31,5	31,5/40	40	31,5	31,5/40	31,5/40/50	31,5/40/50	31,5	40	40	40
Rated short-duration power-frequency withstand voltage $U_d$ (kV)	Common value	140		230	275			275	460			
	Across the isolating distance	160		265	315			315	530			
Rated lightning impulse withstand voltage $U_p$ (kVp)	Common value	325		550	650			650	1050			
	Across the isolating distance	375		630	750			750	1200			
Rated frequency $f_r$ (Hz)	Enel Distribución Chile, Edesur, e-distribucion, Enel Distributie and Enel Distribuzione	50										
	Enel Rio, Ceará, Goiás, Sao Paulo, Enel Codensa and Enel Perú	60										
Opening (closing) time if motor-operated (s)		≤ 15										
Degrees of protection provided by enclosures		IP 54										
Rated supply voltage $U_a$ (Vdc)	Enel Distributie and Enel Distribuzione	110										
	Enel Sao Paulo	48 /125										
	e-distribucion, Enel Rio, Ceará, Goiás, Sao Paulo, Enel Chile, Enel Codensa, Enel Perú	125										
	Edesur	220										
d.c. maximum absorbed power (W)		1000										
Rated supply voltage for anti-condensation circuits (Vac)	e-distribucion, Enel Distributie and Enel Distribuzione	230										
	Enel Rio, Ceará, Goiás, Sao Paulo, Enel Chile, Enel Perú, Edesur	220										
	Enel Codensa	120										
a.c. max absorbed power (VA)	Manual operated DS/ES	50 (only for anti-condensation circuit)										
	Motor operated DS/ES, dc motor (Enel Distribuzione and Latam)	250 (only for anti-condensation circuit)										
	Motor operated DS/ES, ac motor (e-distribucion and Enel Distributie)	1750 (400 Vac 3-phase)										
Auxiliary contact classes (table 6 IEC 62271-1)		1										
DISCONNECTOR:												
Rated normal current $I_r$ (A)		1250	2000	1600	800	1250	2000	3150	1250	800	2000	3150
Rated static mechanical terminal load:	Straight load $F_{a1}$ and $F_{a2}$ (N)	400	400	500	600	600	800	1000	600	800	1000	1500
	Cross load $F_{b1}$ and $F_{b2}$ (N)*	130	130	170	200*	200*	250*	330*	200	270*	330*	500*
	Vertical force $F_c$ (N)	500	500	1000	1000	1000	1000	1250	1000	1000	1250	1500
Mechanical endurance class $M_r$		M1										
Bus-transfer current switching by disconnectors (only if requested)	Rated bus-transfer current for disconnectors (A)	Clause B.4.106.1 of IEC 62271-102										
	Rated bus-transfer voltages for disconnectors (V)	Clause B.4.106.2 of IEC 62271-102										
EARTHING SWITCH:												
Earthing switches class		E0 – M0 – A										

**Note:** For Type Code GSH003/943 (150971), GSH003/944 (990216) and GSH003/945 (990212) the Vdc are 220V.

\*Edesur 500N

**Application Areas**Perimeter: *Global*

Staff Function: -

Service Function: -

Business Line: *Infrastructure & Networks*

## 7.4 CONSTRUCTION CHARACTERISTICS

### 7.4.1 General characteristics

The DS/ESs shall be manufactured in accordance with IEC 62271-102.

The manufacturer will provide all tubes, extensions, bearings and the rest of the necessary materials in order to assemble it properly and adapt it to the support standardized by each company defined in Annex B.

The driving mechanism of the DS and of the ES will be manual-operated or motor-operated.

The upgrading from manual-operated type to motor-operated type shall be possible by retrofit on site, without need of intervention on power contacts, main regulations or on the movement transmission shafts.

The manual-operation of DS and ES (both for motor-operated and for manual-operated DS/ES) shall be compliant with IEC 60447.

All DSs and ESs shall be equipped with mechanical stops for position limits.

IP54 must be accomplished by a specifically designed strip.

### 7.4.2 DS/ES Mechanical interlocking

DS combined with ES as a single unit will have a mechanical interlocking device that prevent the closure of the ES while DS is closed and prevent closure DS while closed ES. Electrical interlockings are described in chapter 7.5.

The mechanical interlocks shall be designed to withstand, preventing damages and without need of maintenance:

- in case of motor-operation, to the strains produced by the other DS/ES motor starting torque;
- on case of manual-operation, to 3 times the maximum force required for manual operation (5.105 of 62271-102), or, if a strain limiting device is present, to 1,5 times its intervention rated value.

### 7.4.3 Insulators

The insulators are requested by Enel Group Distribution companies only in composite materials.

Insulators shall be in light grey color and compliant with IECs in chapter 3.2.1. The envelope shall be made of silicone rubber, HTV type (High Temperature Vulcanized) or LSR type (Liquid Silicone Rubber) and completely free of EPDM or other organic rubbers.

#### 7.4.3.1 *Specific requirements for Chile*

Chile requires insulator with mechanical classification of type C8 for 145kV and type C10 for 245 kV.

#### 7.4.3.2 *Specific requirement for Enel Perú*

Perú requires insulators with mechanical classification of type C8 for 72,5kV and C10 for 220kV

#### 7.4.3.3 *Specific requirements for e-distribucion*

The creepage distance must comply with IEC 60815-3 part 9.7 with no deviations.

### 7.4.4 HV terminals

The HV terminals, DS main contacts and ES contacts shall be manufactured with corrosion resistant copper or aluminum alloy, in order to be interfaced with aluminum alloy connectors or clamps.

**Application Areas**

 Perimeter: *Global*

Staff Function: -

Service Function: -

 Business Line: *Infrastructure & Networks*
**7.4.4.1 Latam**

The terminals shall be rectangular shape with the following dimensions, according to fig. 3 (2x2 hole pattern) or fig. 4 (2x3 hole pattern) of IEC/TR 62271-301:

- Hole diameters  $\varnothing$  14.3mm
- Distance between holes 44.5mm

**7.4.4.2 e-distribucion, E-Distributie and e-distribuzione**

The HV terminals shall be realized with corrosion resistant copper or aluminum alloy, in order to be interfaced with aluminum alloy clamps.

The HV terminals shall have  $\varnothing$  40  $\pm$ 0,25 X 80 (mm) (fig. 1 of IEC/TR 62271-301) dimensions.

**7.4.5 Grounding**

The manufacturer shall ensure the equi-potentiality between all parts forming the equipment.

Inside the Control Box an internal collector (in tin-plated or nickel-plated copper, section  $\geq$  60 mm<sup>2</sup> and with M5 regular interval threaded hole) shall be present for the grounding connection of all cable shields; the manufacturer shall guarantee its effective connection to the DS+ES grounding system.

The support is not allowed as part of the ground connection.

At the base of each support upright shall be provided 2 earthing points, equipped with M12 stainless steel bolts (included in the supply) separated 50 mm vertically.

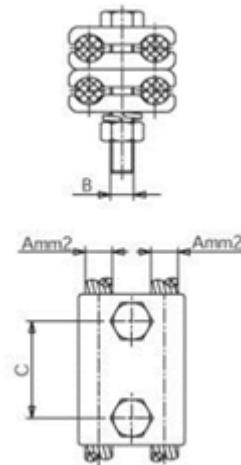
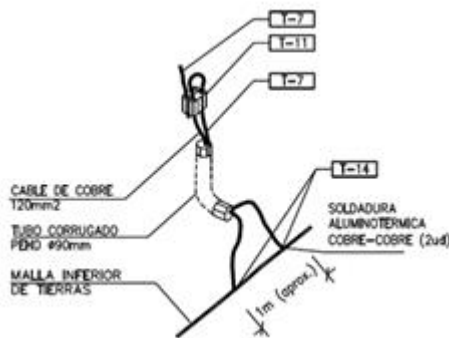

Support cannot be used as earthing path (even for CTs and VTs, that will also have an earthing path connection directly to the earthing points in the support base).

The manufacturer must ensure that the earthing at each of these points independently establishes that all parts of the equipment are equipotential. The equipment does not need additional grounding points to ensure an equipotential bonding of all components.

**7.4.5.1 Specific requirements for Brazil**

For Brazil is required a clamp grounding connector for range 70-120 mm<sup>2</sup> on each base plate and operating mechanism. The connector material shall be copper Alloy (maximum 5% Zinc).

**7.4.6 Control and Operating device Box(es)**

The control box must be build in accordance with IEC 60073.

**Application Areas**Perimeter: *Global*

Staff Function: -

Service Function: -

Business Line: *Infrastructure & Networks*

The location of the control box should always consider pedestrian access to the equipment (projected and/or existing). Always prioritizing to facilitate the access and the operation of this.

The control box and the drive mechanisms with its control devices shall be included in one or two cabinets.

In case of two cabinets all the cable connections of the substation will arrive only to the principal one and the connection to the other is in charge of the manufacturer.

In addition to the IP requirement of table at chapter **¡Error! No se encuentra el origen de la referencia.**, the box protection degree with open doors shall be minimum IP2X.

The entrance of all cables shall be from the Control Box bottom side, where a removable loophole (in aluminum, with useful dimension of 150x100 mm) shall be provided.

Inside all boxes a proper anti-condensation system shall be provided in order to prevent humidity damages and to ensure a proper air replacement.

The anti-condensation circuit shall be one for the overall equipment, supplied in a.c (see table in chapter 5 for the supply rated voltage). It shall be controlled by a humidistat; thermostat is admitted in addition if the manufacturer needs it to comply the minimum ambient temperature requirement. Both shall have fixed regulation (typical regulation values are 60% R.H. and + 5°C) and the contacts shall be connected in parallel.

The anti-condensation circuit shall be protected with a magnetothermic automatic circuit-breaker

The heating elements shall be connected in series in order to open the circuit in case of breaking of an element; a minimum current sensor shall detect and signal the anomaly (obviously not when circuit is OFF for environmental causes).

In the case of a different heating system, the manufacturer must ensure correct fault detection and remote fault signaling in the event of the failure, correctly assessing the tolerances of the supply voltage and components resistance.

The heating elements must be easily removed for maintenance

The box interior shall be accessible from the front by mean of a door provided of handle and lock, hinged and equipped with an anti-wind system. It shall be possible to open the door over 90°. Should not have operational buttons on the external part of the control box.

In case of motor-operated DS/ES all accessories (hand-crank, document pocket etc.) shall be accommodated in the internal part of the box door. In case of manual-operated DS/ES is admitted to locate the hand-crank/swing lever outside the box.

In case of manual-operated DS/ES hand-crank shall have a specific place to store it. The documents shall be accommodated in the internal part of the box door.

All electric equipments components shall be:

- compliant with the respective IEC standards;
- equipped with an identification label indicating the codification used in the functional electric schemes;
- easily accessible for maintenance or substitution operations.
- of typologies for which interchangeable components are easily available in commerce (delivery time within 2 weeks) in the DS and ES destination country.

All components suitable to be replaced (like the heating elements) should be mounted in a DIN bar, with a connection with the terminal block and easy access

In particular, the extractible ones, plug-in connector included, shall be provided with proper anti-mistake coding.

**Application Areas**

 Perimeter: *Global*

Staff Function: -

Service Function: -

 Business Line: *Infrastructure & Networks*

The box internal wiring shall be performed with conductors with adequate section (always  $\geq 1\text{mm}^2$ ), flexible type, compliant with IEC 60332-3-24 and insulated at  $U_0/U = 450/750\text{ V}$ .

The ground connection of any removable panel or door must be done by braided cable.

The cable ends shall be provided of pre-insulated compression type terminals, suitable for the clamps where they have to be connected.

In case of motor-operated DS/ES, the Control Box(es) shall include:

- remote/manual/local selector switch (and/or relay); (no selector for e-distribucion)(Only two positions remote/manual "Servizio/Prova" for Italy)
- control buttons, with the following colors: (no push buttons for e-distribucion)

Operation	e-distribucion Chile, Enel Codensa, Enel Perú, Edesur, E-Distributie and e-distribuzione (according with IEC 60073)	Enel Rio, Enel Ceará, Enel Goiás, Enel Sao Paulo (according with NR10)
Closing	Black "I" on White background	White "L" on Red background
Opening	White "O" on Black background	White "D" on Green background

- magneto-thermic automatic circuit breakers for the supplies protection (motors, lighting lamp, anti-condensation circuits – fuses are not admitted) with auxiliary contacts.
- interface terminal board for substation control system;
- internal lighting lamp (incandescent type are not admitted), with automatic switching in case of open door.

The grounding of a dc supply polarity is not admitted.

If diodes are used for the circuit separations or for the voltage return protection, they shall have inverse voltage  $\geq 3\text{ kV}$ .

The cable trucking systems for the internal wiring shall have sufficient residual space ( $\geq 10\%$  of used volume); the cables shall be anchored in some points in order to avoid their falling.

The cable trunks close to the interface terminal boards shall be used for the control system wiring and cannot be used for the internal wiring.

All the external wiring and cables to the control box must be protected against mechanical damage with rigid or flexible metal conduits.

The control cables as well as the other internal components must comply with characteristics such as: no fire propagation, reduced emission of toxic gases and no corrosive gases emitted.

In addition to the dimensions shown in Annex B, the box base height respect to the ground shall be  $\geq 400\text{ mm}$  and all HMI (Human Machine Interface) elements (controls and signalizations) shall be at  $\leq 1800\text{ mm}$ . The hand-crank/swing lever connection point shall be at  $\leq 1000\text{ mm}$  respect to the ground.

The main contacts position auxiliary contacts can be located in the control box or, in alternative, in a separated external box, providing a proper anti-condensation resistance.

All conductors must arrive at terminal blocks and must have indelible marks indicating the place of Origin / Destination. Only one conductor will be accepted per terminal.

The manufacturer must provide a minimum of 20% of reserve terminal blocks for the Client's use.

The piping inside the cabinets must be run using plastic cable trays. The conductors shall be grouped and attached by means of non-metallic fasteners, suitable for protecting its insulation and support the weight of the cables.

**Application Areas**Perimeter: *Global*

Staff Function: -

Service Function: -

Business Line: *Infrastructure & Networks*

On the lower face of the control box, the connection for low-voltage circuit cables shall be realized preferably with 2" diameter ducts.

Outside the Control box must be avoided spaces where birds could nest or any other animals like for example bees.

**7.4.6.1 e-distribuzione specific requirements**

In alternative to IEC 60332-3-24, cables compliant with Italian standard CEI 20-22/2 and marked with "CEI 20-22 II" can be accepted.

In case of "S/P" relay presence, a white lamp to indicate its activation (Lamp on in case of "P" status) shall be located in the DS Control Box.

It's necessary a space in the control box with a DIN bar width 150mm, height 200mm, depth 150mm for a device DV7203 (conversion digital signal in optical)

Will be provided a contact with the signalization of aperture of external doors (see Annex A)

**7.4.6.2 e-distribucion specific requirements**

Control box wiring and construction must be compliant with internal e-distribucion procedure NMC001, and NNC007.

It must be considered as a low voltage equipment. For that reason it also must be compliant with Reglamento Electrotécnico para Baja Tensión, Real Decreto 842/2002.

The heating elements should be easily replaced without affecting any other component of the enclosure (even wiring) and with the equipment in service.

The insulation material may be thermostable (Z) corresponding to the cable harmonized H07Z-K, or thermoplastic (Z1) for the 07Z1-K Cable and comply with the following requirements:

- Test for resistance to flame propagation conductors individual, according to IEC 60332-1-1
- Testing of no fire propagation according to IEC 60332-3-24, category C
- Testing of the gases evolved during combustion: No emission of halogen gases (IEC 60754-1 and 60754-2) and the weighted value of conductivity is not exceed 10  $\mu$ S/mm (IEC 60754-1 and 60754-2)
- Test for determining the cable smoke density, according to standard IEC 60754-1 and 60754-2, the level of light transmittance will be higher than 60%. The color of insulation is light gray except for earthing protection circuits which will be green-yellow color.

**7.4.6.3 Latam specific requirements**

The internal wiring must be of flexible copper with an operating temperature of 90°C.

**7.4.7 Protective treatments**

All external surfaces shall have an effective and enduring anti-corrosion protection.

On request the enclosures shall be painted in light gray color (RAL 7035). Painting is anyway admitted even if not expressly requested.

All iron parts (e.g. support, Control Box, bolts etc.) shall be in non-corrosive material (AISI 316) or hot dip galvanized in compliance with ISO 1461. All processing shall be completed before the protective treatments.

Protective treatments alternative to the hot dip galvanization could be accepted if the manufacturer prove its fitness.

The metallic elements in contact between them shall be designed in order to avoid corrosion due to humidity galvanic effect.

**Application Areas**Perimeter: *Global*

Staff Function: -

Service Function: -

Business Line: *Infrastructure & Networks***7.4.8 Dimensional characteristics**

Specific dimensional requirements are shown in Annex B.

**7.4.9 Support**

The support is an optional supply. If requested, the DS/ES support shall be compliant with LS6016.

If the support is not requested it must be considered the standard one in order to fix the command box to the columns or to a third small column. The manufacturer must provide the transmission and fixation for the control box to the support even if not requested the support. If it's fixed to a little third column, the column must be also supplied

**7.4.9.1 Enel Distribuzione specific requirements**

The Control Box and Operating device Box(es) support is a mandatory supply always included in the DS/ES supply.

**7.4.10 Nameplates**

The nameplates shall be for external installation in stainless steel. Alternative materials can be considered if the manufacturer proves the marking endurance respect to the ageing (this solution shall be approved by Enel companies).

Par. 5.10 of IEC 62271-102 apply, specifying that both DS/ES nameplate and control box nameplates shall include:

- the optional values;
- the Enel Group type code (see Common List) and the local components codification.

For traceability purpose, in the internal part of the driving mechanism (if any) door shall be located a self-adhesive nameplate with the following information:

- box manufacturer;
- serial number of the Control Box;
- year of construction.
- Only for e-distribuzione shall be also provided in electronic format together with the guarantee and barcode data requested by PVR001 and PVR006 (The file sending modalities will be discussed during the conformity assessment process).
- Only for Latam the self-adhesive nameplate to be located in the internal part of the Control Box door shall also contain the contract number.

**7.5 FUNCTIONAL CHARACTERISTICS****7.5.1 Common requirements****7.5.1.1 General characteristics**

The drive mechanism of the disconnectors and the earthing switches (if any), must guarantee the simultaneous operation of the poles.

The drive mechanism shall operate on a highly reliable transmission system, in order to avoid any interruptions.

The number of turns for a complete manual operation shall not exceed 50.

Centre-break DSs shall have the 2 movable contacts moving in the same direction.

**Application Areas**

 Perimeter: *Global*

Staff Function: -

Service Function: -

 Business Line: *Infrastructure & Networks*

All disconnectors and earthing switches shall be equipped with mechanical stops for position limits. Moreover it shall be possible to lock them at operation limits by mean of padlocks with  $\varnothing = 10$  mm pin.

#### 7.5.1.2 *Motor-operated disconnectors and earthing switches*

The DSs and ESs operation shall be performed by tripolar motor-drive mechanisms with the possibility of emergency manual operation in case of necessity. It will consist of a gear motor (see table in chapter 5 for the supply rated voltage) which will transmit its movement to the drive shaft of the disconnector. The same for the earthing switch.

The motor circuit will be protected by a motor protector for short-circuits and overloads.

DS and ES shall be each one provided of the following circuits:

- a) n° 1 drive circuit of shunt closing release;
- b) n° 1 drive circuit of shunt opening release.

The ongoing operations shall be completed even in case of opposite operation request.

The operation requests persistence after the operation conclusion shall not produce effects.

In case of a DS/ES operation is not completed, any previously received operation requests shall not remain stored. In case of motor supply outage during a DS/ES operation, the drive mechanism shall ensure:

- the keeping of the reached position, both during supply absence and at its restore;
- the execution after the supply restore of any requested closing or opening operation, independently from the operation type ongoing at supply outage instant;
- that in case of not completed operation the operation sequence shall be stopped and an anomaly remote signalization (SNM – “Switch Not Maneuverable”) shall be sent, by mean of a timed contact.

The operations shall not be carried out if the request signal duration is shorter than 3 ms.

The hand-crank for manual operation shall be withdrawable type; its insertion shall disable the electric operations, both local and remote. The motor rotation shall not transmit movement to the hand-crank inserted. Turning sense must be marked close to the insertion site.

The manufacturer shall indicate the auxiliary contact calibration mode.

Further characteristics are specified in local specific requirements.

#### 7.5.1.3 *Manual-operated disconnectors and earthing switches*

The characteristics are specified in local specific requirements.

#### 7.5.1.4 *Electric schemes, controls and signalizations*

The electric schemes shall:

- a) be represented in the reference conventional conditions:
  - a.1) DS/ES (if any) in open position;
  - a.2) DBST not inserted (only for e-distribuzione);
  - a.3) DEC not energized (only for e-distribuzione);
  - a.4) absence of a.c. and d.c. auxiliary supplies;
  - a.5) remote/local selector switch in remote position (or relay, only for e-distribuzione);
  - a.6) in case of micro-switches with the state dependent on the opening/closing of the boxes/carters of operating devices, they shall be represented disable (that is with boxes/carters open), without primary voltage (27) and with the heating in anomaly status.



**Application Areas**Perimeter: *Global*

Staff Function: -

Service Function: -

Business Line: *Infrastructure & Networks*

- b) contain the functional scheme, all information useful to identify the single wires and cables, the equipments wiring schemes (auxiliary contacts, relays etc.), the topographic schemes for interconnections between boxes, the topographic schemes about all the electric components in Control box/Operating device box(es), the anti-mistake coding.

The principle electric schemes of the different DS/ES typologies are represented in Annex A, including the interface terminal board for substation control system and the auxiliary signalling contacts characteristics.

**7.5.2 e-distribucion and E-Distributie functional characteristics***7.5.2.1 Disconnectors*

The manual drive mechanism will have a signalling box with 6 closing contacts and 6 opening contacts, potential free.

*7.5.2.2 Earthing switch*

The drive mechanism of the earthing switches (if any) will be manual-operated or motor-operated.

Characteristics of the motor-operated drive mechanism are defined in section 7.1.2.

The manual-operated drive mechanism will have a signalling box with 4 closing contacts and 4 opening contacts, potential free, whose characteristics are defined in section 6.6 of this Standard.

*7.5.2.3 Motor-operated disconnectors and earthing switches*

All electric equipments components shall be compliant with the respective IEC standards.

The set of auxiliary contacts designed for the control of the switchings typical of the DS/ES and the sets of additional auxiliary contacts will be actuated by the actuation mechanism.

The electric diagram appears in Annex A.

**7.5.3 e-distribuzione functional characteristics***7.5.3.1 DS/ESs applications*

Application descriptions of the different DS/ES typologies and the relative reference electric schemes are listed in the following table:

**Application Areas**

 Perimeter: *Global*

Staff Function: -

Service Function: -

 Business Line: *Infrastructure & Networks*

Type Code (see Annex D)	Enel Distribuzione codification (see Annex D)	Application description	Reference electric schemes (see Annex A.2)
GSCH003/001	156110	Line DS+ES motor-operated	Fig. A.2.1 + Fig. A.2.9
GSCH003/002	156111	Line DS+ES manual-operated	Fig. A.2.2 + Fig. A.2.9
GSCH003/003	156112	Busbar DS (line bay) manual-operated	Fig. A.2.3
GSCH003/004	156113	Busbar DS (transformer bay) manual-operated	Fig. A.2.4
GSCH003/005	156114	Conjoint busbar DS manual-operated	Fig. A.2.5
GSCH003/006	150003	Busbar DS (line bay) motor-operated	Fig. A.2.6
GSCH003/007	150004	Busbar DS (transformer bay) motor-operated	Fig. A.2.7
GSCH003/008	150005	Conjoint busbar DS motor-operated	Fig. A.2.8

**7.5.3.2 Motor-operated DS and ES**
**7.5.3.2.a) Control circuits of motor-operated DS and ES**

DS local controls (motor or manual) shall be enabled by consensus (“Prova”) coming from line bay Circuit Breakers, working on the “S/P” relay (servizio/prova<sup>4</sup>), located in its control box.

Usually the remote controls are enabled and the local controls are inhibited; with the “Prova” consensus it’s the opposite.

Earthing switch local controls (motor or manual) shall be subject to the remote/local switch (“Servizio/Prova”) located in its control box.

**7.5.3.2.b) Blocking devices/circuits of motor-operated DS and ES**

During normal operation, temporary block signalizations shall not be sent to the control system.

**Closing block**

The closing operation block (motor and manual) shall work when occurring at least one of the following conditions:

- a) DS
  - Circuit Breaker closed
  - ES closed
- b) ES
  - DS closed
  - line voltage presence

<sup>4</sup> In Italian “Prova” means “Test” and “Servizio” means “In service”

**Application Areas**Perimeter: *Global*

Staff Function: -

Service Function: -

Business Line: *Infrastructure & Networks*Opening block

The opening operation block (motor and manual) shall work when occurring at least one of the following conditions:

- a) DS
  - Circuit Breaker closed
- c) ES
  - line voltage presence
  - DBST inserted

*7.5.3.2.c) Manual operation of motor-operated DS and ES*

The manual emergency operation shall be enabled by a Consensus Electromagnetic Device (DEC – “Dispositivo Elettromagnetico di Consenso”) (three if ES is present, one for DS, one for ES and one for DBST); with this device the hand-crank insertion is enabled pressing a button<sup>5</sup> and in presence of external consensus “Prova” and of all requested conditions (see electric schemes).

The DEC shall be immune to possible malfunctions due to the residual magnetism.

The DEC status (energized/de-energized) shall be clearly visible.

With the hand-crank insertion an anomaly remote signalization (SNM) shall be sent.

*7.5.3.2.d) ES blocking device (DBST)*

The motor-operated ES shall be provided of a device for the earthing switch locking (DBST - “Dispositivo Elettromeccanico di Blocco Sezionatore di Terra”), subject to the ES remote/local switch (“Servizio/Prova”) located in its control box.

All requirements of clauses 7.5.1.2 and 7.5.3.2.c) are entirely applicable to the DBST (“SNM” signalization becomes “DBST NM”).

The DBST operation (motor or manual) shall be subjected to the ES in closed position; its insertion shall operate mechanically (operating directly on the mechanical transmission system) and electrically on the ES, avoiding its opening (motor or manual) and interrupting the motor supply.

The DBST operating device shall be preferably located in the ES operating device box.

The DBST insertion/exclusion circuits shall be electrically interlocked between them.

The access to internal part of DBST shall inhibit operations and shall generate a remote signal (“Blocco Violato”).

The inserted/not inserted DBST signalizations (“DBST INSERITO”, “DBST DISINSERITO”) shall be provided by mechanically independent auxiliary contacts, directly actuated by extreme position limits of the lock unit.

*7.5.3.3 Manual-operated DS and ES**7.5.3.3.a) Control circuits of manual-operated DS and ES*

DS manual operation shall be enabled by consensus (“Prova”) coming from the correspondent bay Circuit Breakers (line bay or transformer bay), working on the “S/P” relay (servizio/prova), located in its control box. This consensus is not present for Conjoint busbar DS.

---

<sup>5</sup> Different designs with the same functional results can be evaluated by Enel.

**Application Areas**

 Perimeter: *Global*

Staff Function: -

Service Function: -

 Business Line: *Infrastructure & Networks*
**7.5.3.3.b) Blocking devices/circuits of manual-operated DS and ES**

The manual-operation block (opening/closing) shall work when occurring the following conditions:

- a) Line DS+ES manual-operated:
  - a1) DS
    - Circuit Breaker closed
    - ES closed
  - a2) ES
    - DS closed
    - Line voltage presence
- b) Busbar DS (line bay) "189SB(L)":
  - Circuit Breaker closed
- c) Busbar DS (transformer bay) "189TR":
  - It shall be realized a key interlock between the DS "189 TR" and the earthing switch on the MV side of the HV/MV transformers "89 T TR", in order to make impossible the DS "189 TR" closing with the MV side earthing switch "89 T TR" closed, and viceversa.  
This function shall be realized with an electromagnetic device enabling rotation and extraction of a key, to which is combined another key enabling closing of the MV side earthing switch "89 T TR".  
The device, with its button activated, is energized with DS "189 TR" open in presence of "Prova" external consensus coming from transformer bay Circuit Breaker.
- d) Conjoint busbar DS "189SB":
  - the operation shall be enabled only if all Circuit Breakers of one of the 2 semi-busbars are open (absence of energy flowing between the two HV semi-busbars).

**7.5.3.3.c) Manual operation of manual-operated DS and ES**

The manual operation shall be enabled by a Consensus Electromagnetic Device (DEC) (two if ES is present, one for DS and one for ES); with this device the hand-crank insertion (or the swing lever operation) is enabled pressing a button<sup>6</sup> and in presence of all requested conditions (see electric schemes). In case of swing lever operation the DEC blocking system shall be designed to withstand 3 times the maximum force required for manual operation (5.105 of 62271-102).

The DEC shall be immune to possible malfunctions due to the residual magnetism.

The DEC status (energized/de-energized) shall be clearly visible.

If closing or opening operation is not fully completed an anomaly remote signalization (MNC – "Manovra Non Completata") shall be sent.

Moreover, with the hand-crank insertion an anomaly remote signalization shall be sent using MNC signalization (not represented in the electric scheme, because not necessary in case of swing lever with an operation enabling).

**7.5.3.4 Controls and signalizations**

The contacts referred to the following controls and signalizations shall be reported in the terminal board, when they are necessary:

- a) drive circuit of shunt closing release control (CH, for DS and ES)

<sup>6</sup> Different designs with the same functional results can be evaluated by Enel.

**Application Areas**

 Perimeter: *Global*

Staff Function: -

Service Function: -

 Business Line: *Infrastructure & Networks*

- b) drive circuit of shunt opening release control (AP, for DS and ES)
- c) drive circuit of DBST insertion control (INS)
- d) drive circuit of DBST de-insertion control (DIS)
- e) consensus "P" (Prova) to local operations
- f) remote/local selector switch in local (P) position (43SP-Prova)
- g) intervention of motor protection device and/or auxiliary supply missing (42RT)
- h) motor maximum operation time (BX)
- i) not-maneuverable DS (SNM, only in case of motor-operated, for DS and ES)
- j) not completed manual operation (MNC) (only in case of manual-operated, for DS and ES)
- k) close position (ccX189, for DS and ES)
- l) open position (caX189, for DS and ES)
- m) anti-condensation circuit anomaly (AnR189)
- n) consensus from on-site switchgears CBs (152), DS and ES (189).

Further specific control circuits, using signals from secondary terminals of on-site Inductive or Capacitive Voltage Transformers (see electric diagrams), elaborate absence of voltage on HV line (and status ON/OFF of relative low voltage protection CBs) to enable the ES closing:

- a) voltage presence (27ON)
- b) voltage absence (27OFF)
- c) voltage presence anomaly (An PRES TENS)

For this purpose the low voltage components shall have the following characteristics:

- a) 3P+N circuit-breaker for protection of secondary VT circuits:  
 $U_e = 400 \text{ V ac}$ ;  $I_n = 3\text{A}$ ; Electromagnetic over current release - short circuit current setting: 12 A ("MA-type");  $I_{cu} \geq 25 \text{ kA}$ ;
- b) 1 auxiliary contact discordant
- c) 1 auxiliary contact concordant (advanced in opening and delayed in closing)
- d) K27A/L, K27B/L and K27ATL relays:  
 Rated voltage = 100 V AC.

#### 7.5.4 Latam functional characteristics

##### 7.5.4.1 Operating mechanisms. General characteristics

For 3-column disconnectors, the rotation blades opening will be clockwise direction (seen from above).

##### 7.5.4.2 Motor-operated and manual-operated disconnectors and earthing switches

In case the motor-operated, the manual emergency operation shall be enabled by a Consensus Electromagnetic Device (DEC) (two if ES is present, one for DS and one for ES); with this device the handcrank insertion is enabled pressing a button<sup>7</sup> and in presence of all requested conditions. With the handcrank insertion an anomaly remote signalization (SNM) shall be sent.

A switch shall be to permit the selection of operation mode to 3 positions: "local, locked, remote" with auxiliary contacts that indicate the position. In the position, "local," the electric remote control shall be

<sup>7</sup> Different designs with the same functional results can be evaluated.

**Application Areas**

 Perimeter: *Global*

Staff Function: -

Service Function: -

 Business Line: *Infrastructure & Networks*

inoperable. In the position, "remote," the local electric control shall be inoperable. In the position, "locked," local and remote electric operations must be blocked.

In the case of motor-operated, must include an operations meter for the disconnecter.

The set of control contacts designed for the control of the switchings typical of the disconnecter and the sets of additional auxiliary contacts will be actuated by the actuation mechanism.

The DS and ES, both manual and motorized, shall have auxiliary contacts for remote indication of their position. Microcontact auxiliary schemes inserted in the electronic cards will not be accepted.

The DS and ES shall have a running switch limit to indicate the open or closed position of the blades. These must allow an adjustment of  $\pm 10^\circ$ .

For manual-operated, the contacts shall be included in a metal box appropriate for outdoor. In all cases, the auxiliary contacts shall be operated directly by the disconnecter's drive shaft.

The quantities of auxiliary contacts: normally open (NO) and normally close (NC) are indicated in the following table for DS and ES:

Company	72,5 [kV]		145 [kV]		245 [kV]	
	DS	ES	DS	ES	DS	ES
Enel Rio, Ceará, Goiás, Sao Paulo	6NO/6NC	4NO/4NC	6NO/6NC	4NO/4NC	-	
Enel Distribución Chile	-		6NO/6NC	4NO/4NC	6NO/6NC	4NO/4NC
Enel Codensa	-		6NO/6NC	4NO/4NC	6NO/6NC	4NO/4NC
Enel Perú	8NO/8NC	4NO/4NC	-		8NO/8NC	4NO/4NC
Edesur	-		10NO/10NC	6NO/6NC	10NA/10NC	6NA/6NC

Further requirements are specified in next paragraphs and in the electric scheme in Annex A.

## 7.6 TESTING

### 7.6.1 General information

The tests will be performed according to Standards IEC 62271-1 and IEC 62271-102.

The tests to be performed on DS/ESs are divided in:

- Type tests;
- Routine tests;
- Commissioning tests.

### 7.6.2 Type tests

#### 7.6.2.1 Visual inspection

The DS/ES, complete of all accessories and fully assembled in operation layout, shall be subject to a visual inspection in order to verify its functional, dimensional and constructive compliance with this Global Standard.

#### 7.6.2.2 Dielectric tests

(IEC 62271-102 par. 6.2)

#### 7.6.2.3 Radio interference voltage (r.i.v.) tests

(IEC 62271-102 par. 6.3)

Not applicable for 72,5 kV DS/ES.

#### 7.6.2.4 Measurement of the resistance of the main circuit

(IEC 62271-102 par. 6.4)

**Application Areas**Perimeter: *Global*

Staff Function: -

Service Function: -

Business Line: *Infrastructure & Networks***7.6.2.5 Temperature-rise tests**

(IEC 62271-102 par. 6.5)

**7.6.2.6 Short-time withstand current and peak withstand current tests**

(IEC 62271-102 par. 6.6)

**7.6.2.7 Verification of the degree of protection**

(IEC 62271-102 par. 6.7)

**7.6.2.8 Electromagnetic compatibility (EMC) tests**

(IEC 62271-102 par. 6.9)

**7.6.2.9 Additional tests on auxiliary and control circuits**

(IEC 62271-1 par. 6.10)

For this verification the manufacturer shall provide a paper copy of the DS/ES electric schemes.

The correct operation of all controls, interlocking and signalizations shall be also verified.

The absorption curves of the motors, taking note of the maximum values (inrush excluded), shall be registered in the following situations:

- at rated voltage;
- at 110% of the rated voltage;
- at 85% of the rated voltage.

**7.6.2.10 Operating and mechanical endurance tests**

(IEC 62271-102 par. 6.102)

Note: par. 6.102.3.2 applies also to measuring of resistance of earthing switch.

**7.6.2.11 Operation under severe ice conditions**

(IEC 62271-102 par. 6.103)

This test is mandatory in case of ice coating higher than 1 mm.

Note: par. 6.103.4.2 applies also to measuring of resistance of earthing switch.

**7.6.2.12 Operation at the temperature limits.**

(IEC 62271-102 par. 6.104)

This test is mandatory.

**7.6.2.13 Bus-transfer current switching tests**

(IEC 62271-102 par. 6.106)

Tests is mandatory only for Disconnectors for which this characteristic is requested (see Annex D).

**7.6.2.14 Induced current switching tests**

(IEC 62271-102 par. 6.107)

This test is mandatory.

**7.6.2.15 Seismic qualification**

If requested, DS/ES (including the support) shall be compliant with seismic qualification, according with standards listed in 7.2.2.2.

**7.6.2.16 Protective treatments**

Hot dip galvanized coatings on iron and steel components shall be verified in accordance with ISO 1461 by mean of magnetic flux equipments, performing at least 5 measures on each component, in uniform manner on the various surfaces, avoiding edges and angular parts.

**Application Areas**Perimeter: *Global*

Staff Function: -

Service Function: -

Business Line: *Infrastructure & Networks*

The verification of other protective coatings shall be performed considering their characteristics: the manufacturer will indicate the minimum thickness allowed and the others characteristics.

*7.6.2.17 Tests on insulators*

The composite insulators shall be tested in accordance with IEC 61462, IEC 60587, IEC TS 62073 and IEC TS 62039.

**7.6.3 Routine Tests**

The Routine tests shall be made in the manufacturer's factory on each apparatus supplied, to ensure the product compliance with the sample approved during the conformity assessment (homologation, certification etc.) process and on which the type tests have been performed.

The routine tests are for the purpose of revealing faults in material or construction. They do not impair the properties and reliability of a test object. The routine tests shall be made wherever reasonably practicable at the manufacturer's works on each apparatus manufactured, to ensure that the product is in accordance with the equipment on which the type tests have been passed. By agreement, any routine test may be made on site.

If for a DS/ES the erection and commissioning tests assistance are requested to be performed by the manufacturer, the fully assembling in factory is not required.

Test values/results shall be in compliance with rated values (and relative tolerances).

The manufacturer shall provide, for each DS/ES supplied, the report of all measures and tests carried out.

*7.6.3.1 Dielectric test on the main circuit*

(IEC 62271-102 par. 7.1)

Accordingly with 7.1 of 62271-1 the test is fulfilled with the test in 7.6.3.4.

*7.6.3.2 Tests on auxiliary and control circuits*

(IEC 62271-102 par. 7.2)

To be performed if auxiliary and control circuits are present.

The possibility to perform this test without connecting the Control Box(es) to the power kinematic chain shall be approved during conformity assessment process, considering the specific manufacturer design (fully functional tests will be performed on the completely assembled DS/ES on site).

Functional tests (par. 7.2.2 of IEC 62271-1) shall be done only at rated voltage.

Dielectric tests (par. 7.2.4 of IEC 62271-1) shall be done applying 1 kV for 1 s.

Electronic devices, motors etc. can be excluded by dielectric test only if agreed during the conformity assessment (homologation, certification etc.) process.

*7.6.3.3 Measurement of the resistance of the main circuit*

(IEC 62271-102 par. 7.3)

The ambient temperature influence can be neglected.

*7.6.3.4 Design and visual checks*

(IEC 62271-102 par. 7.5)

The checks shall be performed referring to conformity assessment (homologation, certification etc.) documents and verifying damage absence.

*7.6.3.5 Mechanical operating tests*

(IEC 62271-102 par. 7.101)

*7.6.3.6 Protective treatments*

The thickness of the protective coatings shall be verified according with 7.6.2.16.



**Application Areas**

 Perimeter: *Global*

Staff Function: -

Service Function: -

 Business Line: *Infrastructure & Networks*
**7.6.4 Commissioning tests**

The manufacturer shall indicate in the manual the checks and tests to be done after the erection (see 10.2.5 of 62271-1), consisting at least in:

- a) Visual check;
- b) Tests on auxiliary and control circuits (if any);
- c) Measurement of the resistance of the main circuit (after mechanical operating tests);
- d) Mechanical operating tests.

In case of erection and commissioning tests performed by Enel group personnel, if any problem occurs or any commissioning test has negative result, the manufacturer shall intervene in field to verify and solve the problem.

**7.7 SUPPLY REQUIREMENTS**
**7.7.1 Tender's technical documentation**

For each DS/ES typology offered in the tender the supplier shall provide the Annex C properly filled.

**7.7.2 Conformity assessment**
*7.7.2.1 Conformity assessment process*

The conformity assessment processes (homologation, certification etc.) are specified in the proper contractual documents.

*7.7.2.2 TCA documentation (Technical Conformity Assessment)*

The project documentation that the supplier uses to manufacture each DS/ES typology can be divided in Type A documents (public, not confidential) and Type B document (confidential).

For each Enel Group Distribution company requesting a specific DS/ES typology, the manufacturer shall provide a specific documentation set according with the specific requirements stated in this document.

The Type A documentation shall consist at least in:

- 1) Type A documents list;
- 2) Type B documents list;
- 3) Annex C properly filled;
- 4) Overall dimensions drawing;
- 5) Insulators drawings and characteristics;
- 6) Electric diagram (see 7.5.1.4-b), low voltage components list included;
- 7) Control Box (if any) layout drawings;
- 8) Overall DS/ES and Control Box (with open/closed doors) pictures;
- 9) Nameplate and labels drawings; (local language)
- 10) DS/ES installation, use and maintenance handbook/manual; (local language)
- 11) Routine and commissioning tests:
  - a) Test report form (two documents, one for factory tests and one for on-site tests);
  - b) Reference values table (with tolerances);
  - c) Protective coatings (typology, minimum thickness, reference standards);
- 12) List of documentation, materials and accessories supplied;
- 13) Main sub-components suppliers list;
- 14) Only for e-distribuzione, Manufacturing and Control Plan (PFC).

**7.7.3 Packaging, transport, storage and installation/testing**

Par. 10.1 and 10.2 of IEC 62271-102 applies.

**Application Areas**Perimeter: *Global*

Staff Function: -

Service Function: -

Business Line: *Infrastructure & Networks*

In order to limit the on-site mounting operations the DS/ES shall be transported in subassemblies consisting in the single poles fully mounted (this requirement is not mandatory for 245 kV DSs).

DS/ESs' package shall be suitable to guarantee:

- the protection during transport (including by ship, if necessary);
- an elevation from the ground at least of 100 mm;
- the external storage for at least three months.

On external side of packaging, the following information shall be present:

- 1) manufacturer name;
- 2) manufacturing year/month;
- 3) manufacturer designation type;
- 4) manufacturer serial number;
- 5) Enel component codification (i.e.: GSCH003/1 – 156110);
- 6) contract number;
- 7) destination substation;
- 8) total weight;
- 9) lifting information (showing the points and the correct method of lifting);
- 10) only for e-distribuzione, the bar code, in accordance with PVR006.

With each DS/ES the following items shall be supplied (items from 4 to 8 on paper):

- 1) the support structure (only if requested) with its anchor bolts to the civil works (stainless or hot dip galvanized steel, chemical or expansion type);
- 2) bolts to assembly the DS/ES poles to support structure;
- 3) hand-crank or swing lever and Control Box(es) support with its anchor bolts to the civil works;
- 4) list of documentation, materials and accessories supplied;
- 5) overall dimensions drawing;
- 6) electric diagram;
- 7) DS/ES installation, use and maintenance handbook/manual (local language);
- 8) routine and commissioning tests:
  - a) routine (factory) test reports;
  - b) reference values table (with tolerances);

If on-site assembly is performed by the manufacturer, waste (including packaging) shall be disposed by him.

Wooden boxes will be treated, according to international requirements for the control of pests, avoiding the compound "Pentachlorophenol" and "Creosote". The treatment must contemplate, at least: high toxicity to xylophagous organisms, high penetrability and fixation power, chemical stability, non-corrosive substances to metals or that affect physical characteristics of the wood.

#### 7.7.3.1 *Specific requirement for e-distribucion*

The manufacturer must present the declaration of conformity in compliance with ITC-RAT 03 of the "Reglamento sobre condiciones técnicas y garantías de seguridad en instalaciones eléctricas de alta tensión, Real Decreto 337/2014."



**Application Areas**

Perimeter: *Global*

Staff Function: -

Service Function: -

Business Line: *Infrastructure & Networks*

**ANNEX A – ELECTRICAL SCHEMES**

**A.0 General requirements**

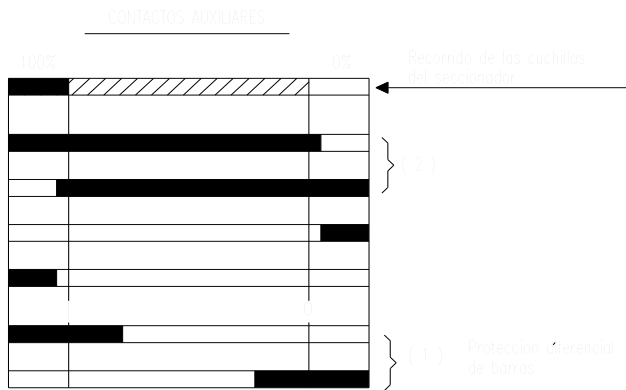

**Application Areas**

Perimeter: *Global*

Staff Function: -

Service Function: -

Business Line: *Infrastructure & Networks*

**A.1 – e-distribucion, E-DISTRIBUTIE AND LATAM ELECTRICAL SCHEMES**

**A.1.1 MANUAL SCHEMES**

**FINAL TERMINAL STRIP MANUAL DRIVING DEVICE**

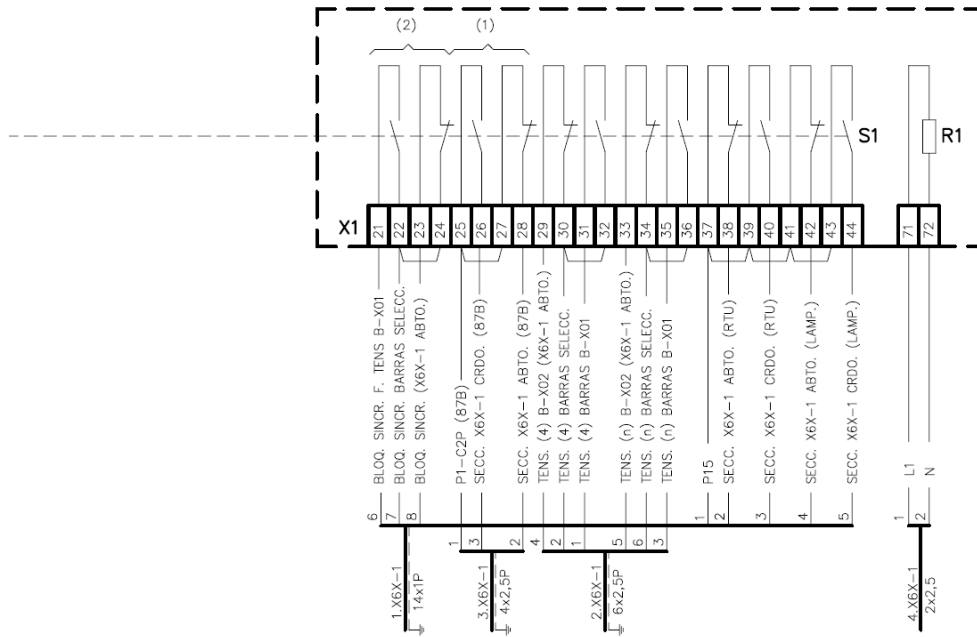

**FINAL TERMINAL STRIP ES DS**

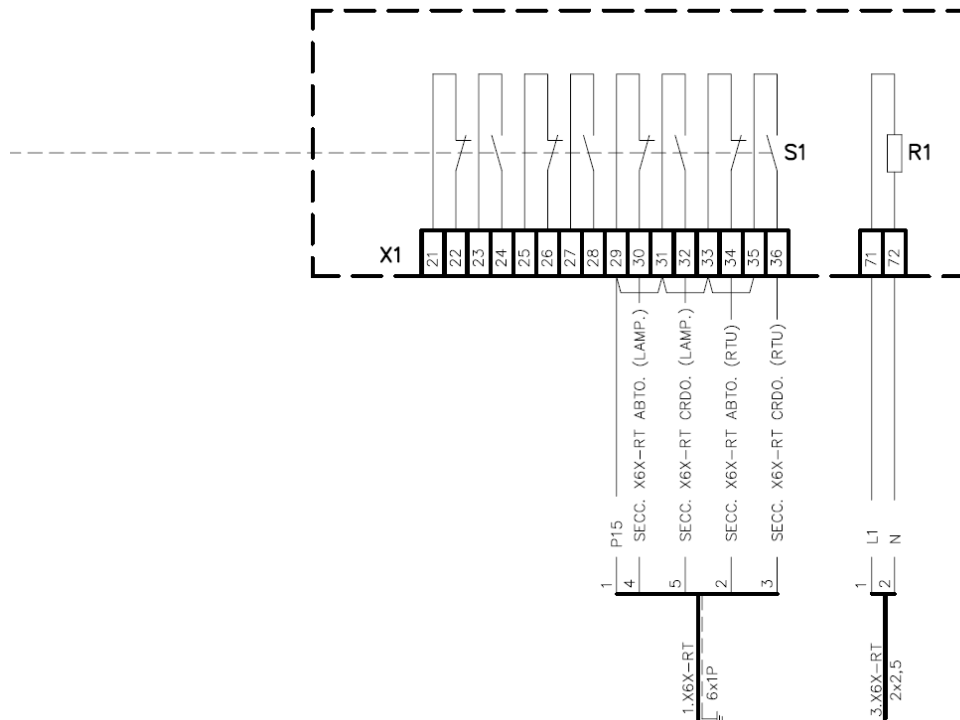



**Application Areas**

Perimeter: *Global*  
 Staff Function: -  
 Service Function: -  
 Business Line: *Infrastructure & Networks*

**A.2 – E-DISTRIBUZIONE ELECTRICAL SCHEMES**

Fig. A.2.1.Motor-operated line DS+ES electrical scheme

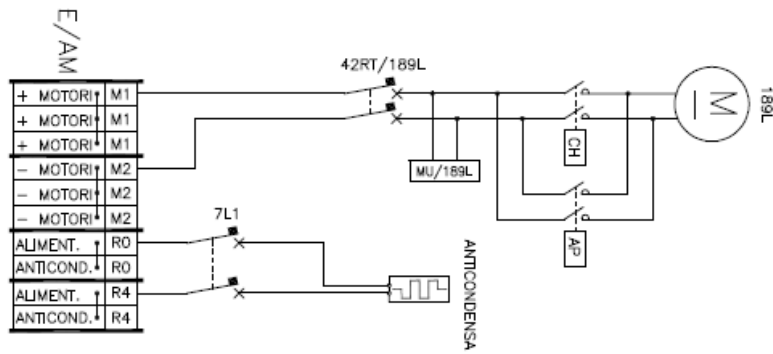

Lo schema è rappresentato con sezionatore aperto e in assenza di tensione

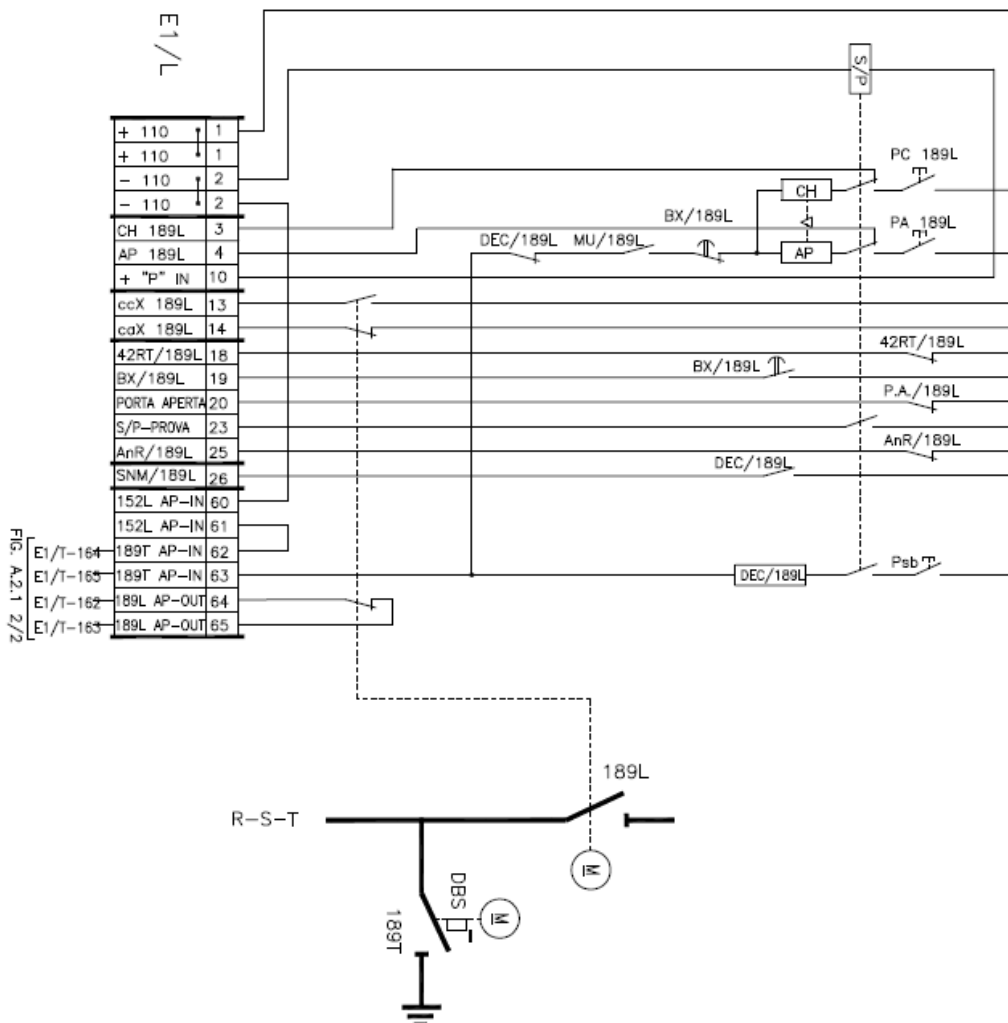

FIG. A.2.1 2/2

Fig. A.2.1 – SEZIONATORE DI LINEA (motorizzato)

**Application Areas**

Perimeter: Global

Staff Function: -

Service Function: -

Business Line: Infrastructure & Networks

Lo schema è rappresentato con sezionatore aperto, DBS disinserito e in assenza di tensione

FIG. A.2.1 1/2

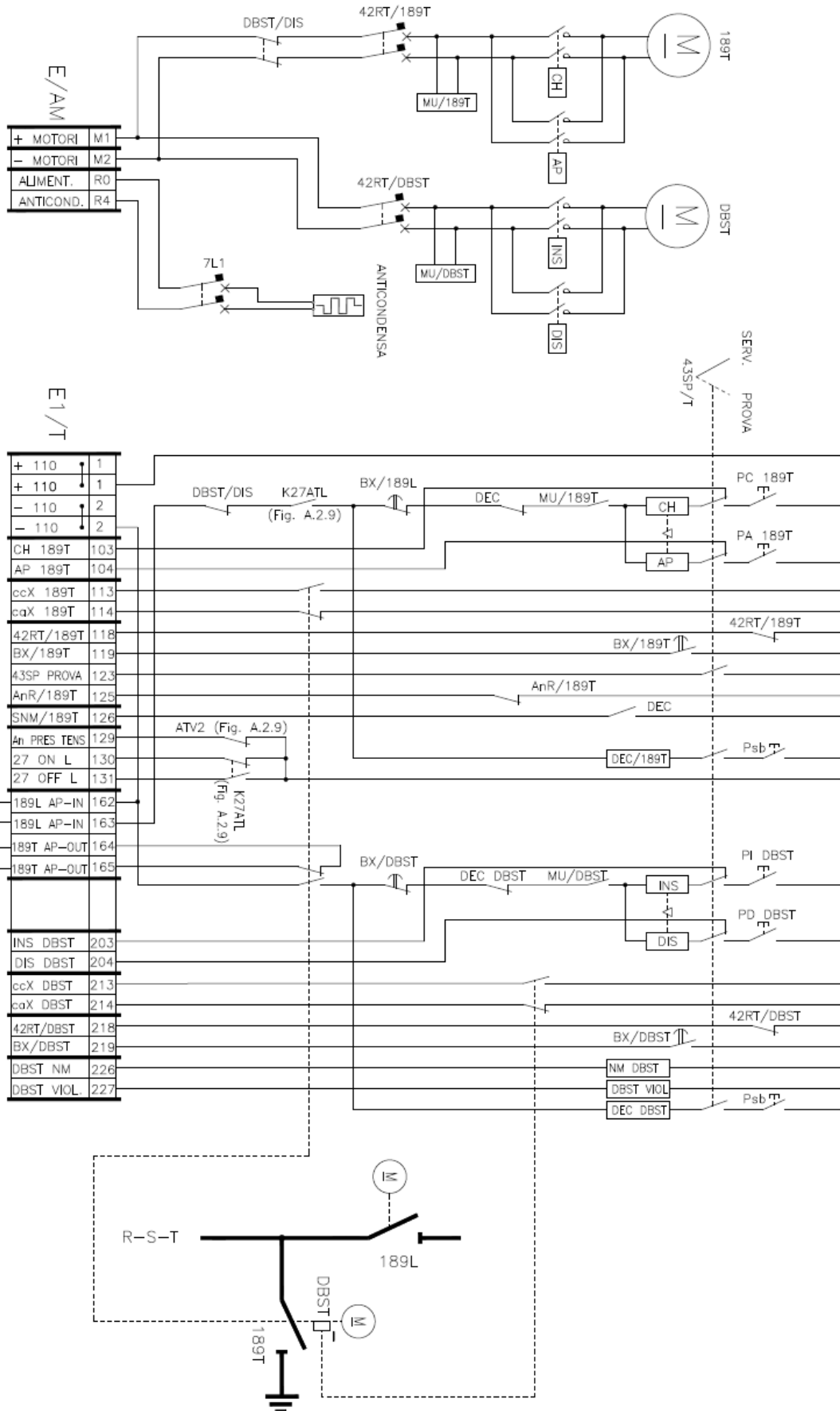

Fig. A.2.1 - SEZIONATORE DI TERRA (motorizzato)

**Application Areas**

Perimeter: *Global*

Staff Function: -

Service Function: -

Business Line: *Infrastructure & Networks*

Fig. A.2.2 (manual-operated line DS+ES electrical scheme pag. 1/2)

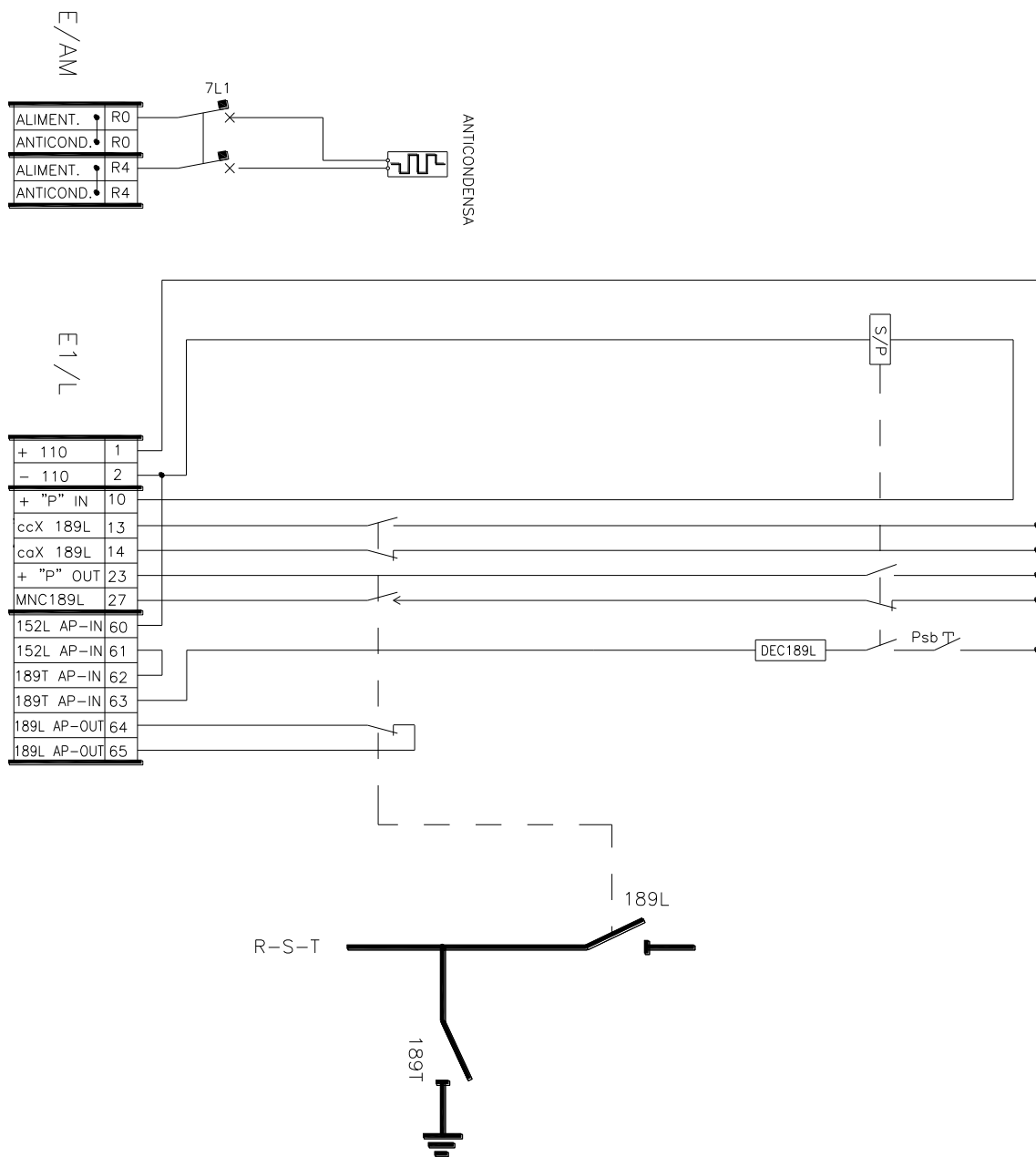



**Application Areas**

Perimeter: *Global*

Staff Function: -

Service Function: -

Business Line: *Infrastructure & Networks*

Fig. A.2.2 (manual-operated line DS+ES electrical scheme pag. 2/2)

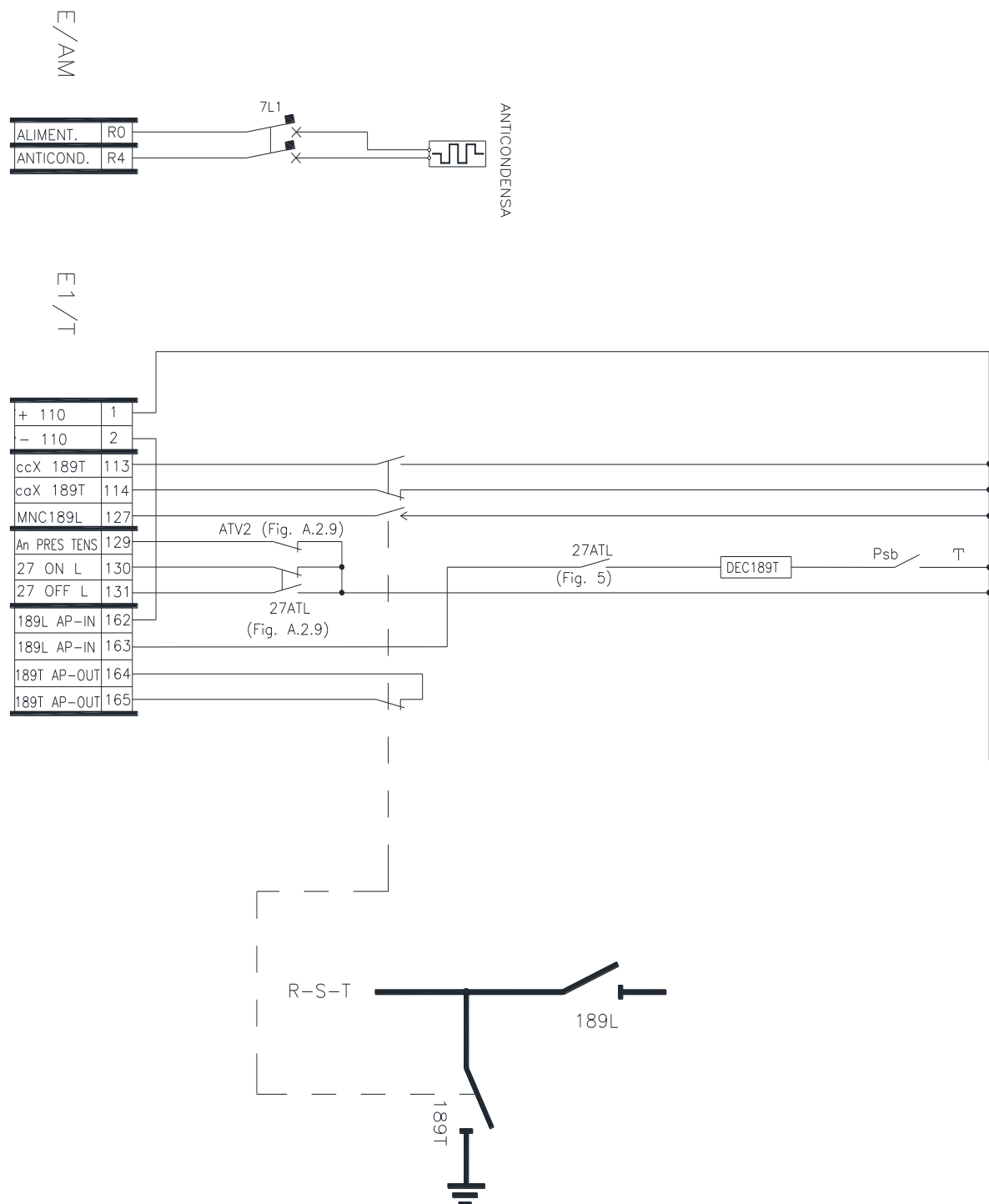

**Application Areas**

Perimeter: *Global*

Staff Function: -

Service Function: -

Business Line: *Infrastructure & Networks*

Fig. A.2.3. Manual operated Busbar DS (line bay)

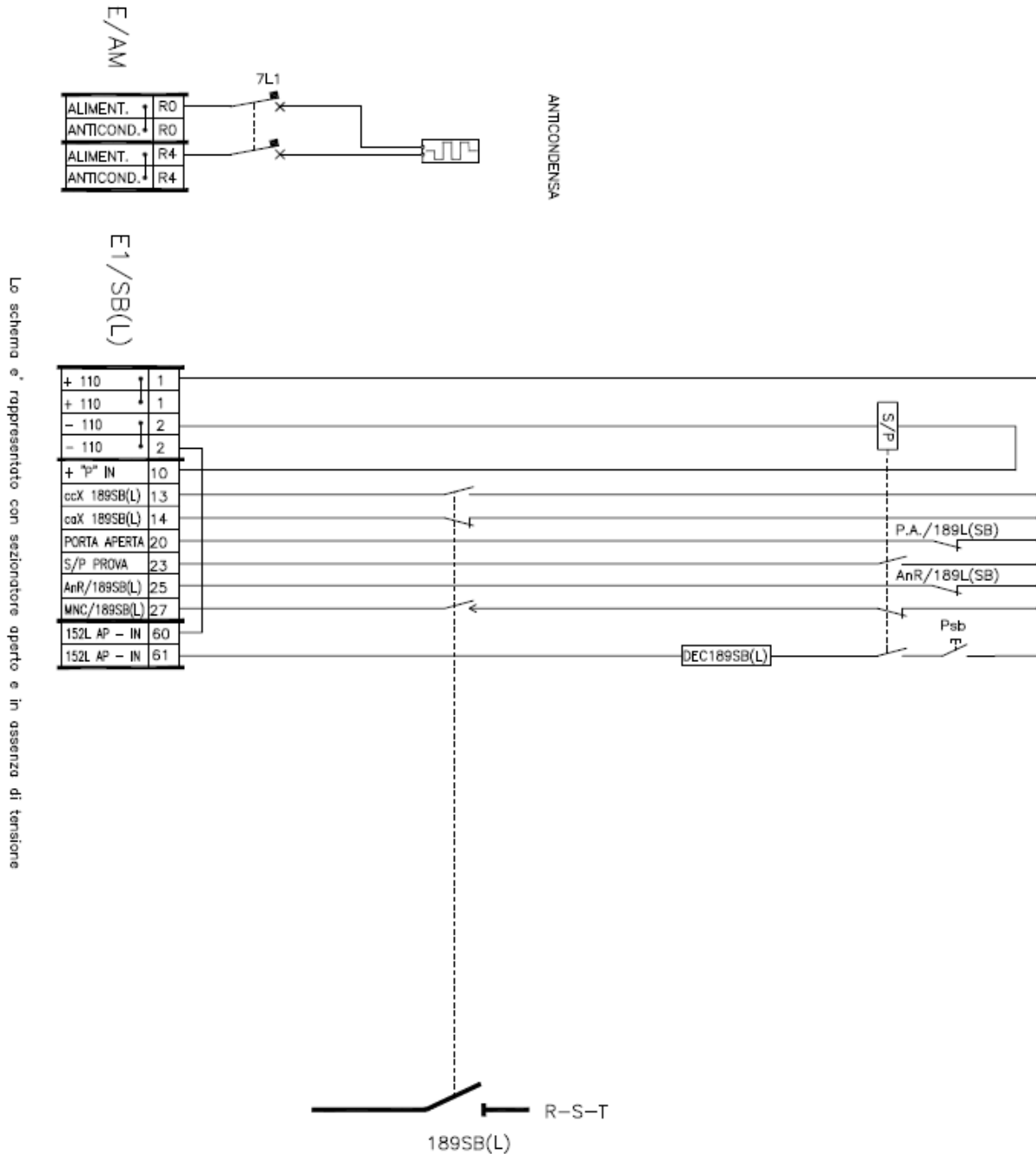

Fig. A.2.3 - SEZIONATORE SBARRA STALLO LINEA (manuale)

**Application Areas**

Perimeter: *Global*

Staff Function: -

Service Function: -

Business Line: *Infrastructure & Networks*

Fig. A.2.4 (manual-operated Busbar DS (transformer bay) electrical scheme)

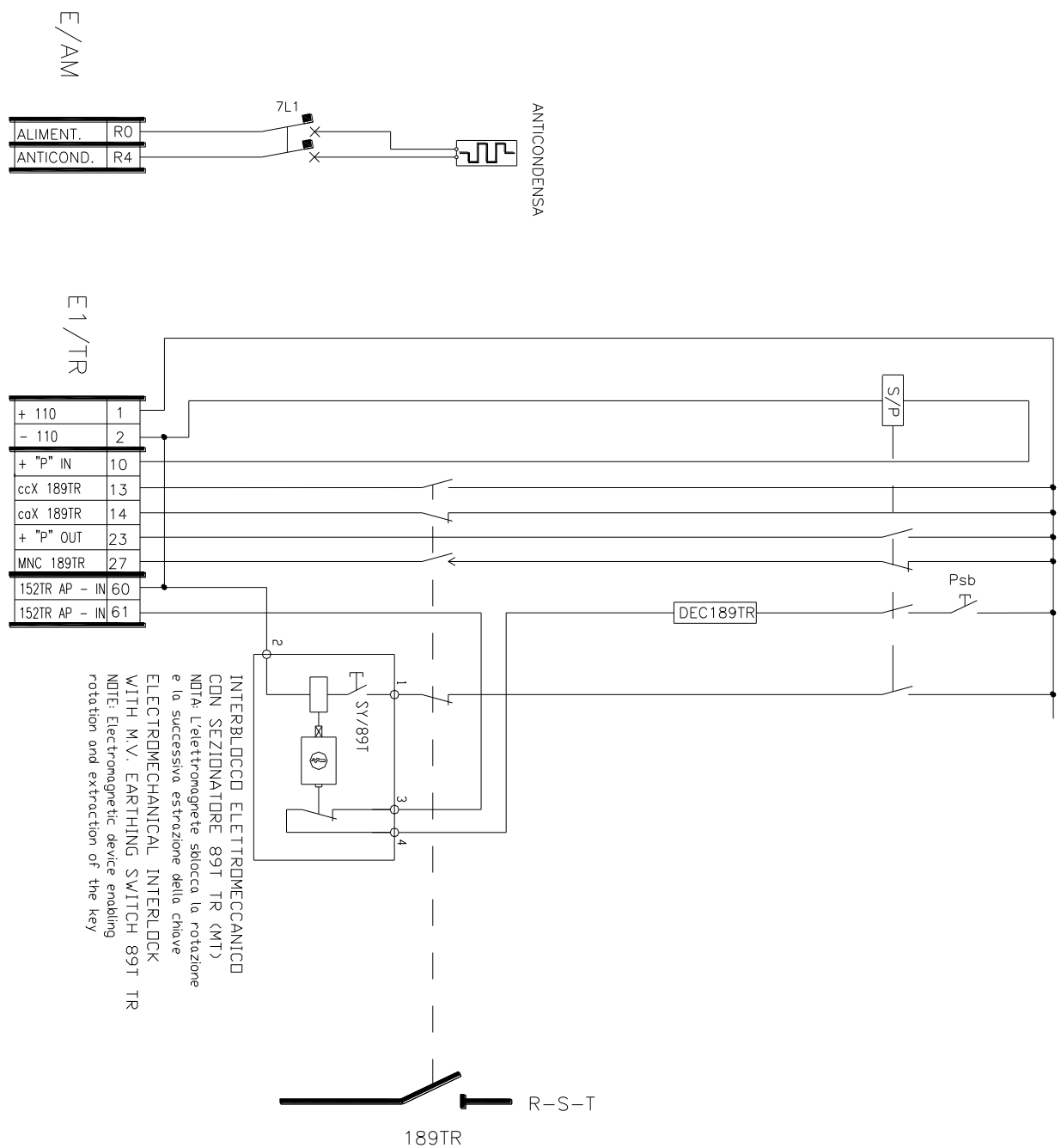

**Application Areas**

Perimeter: *Global*

Staff Function: -

Service Function: -

Business Line: *Infrastructure & Networks*

Fig. A.2.5 (manual-operated Conjoint busbar DS electrical scheme)

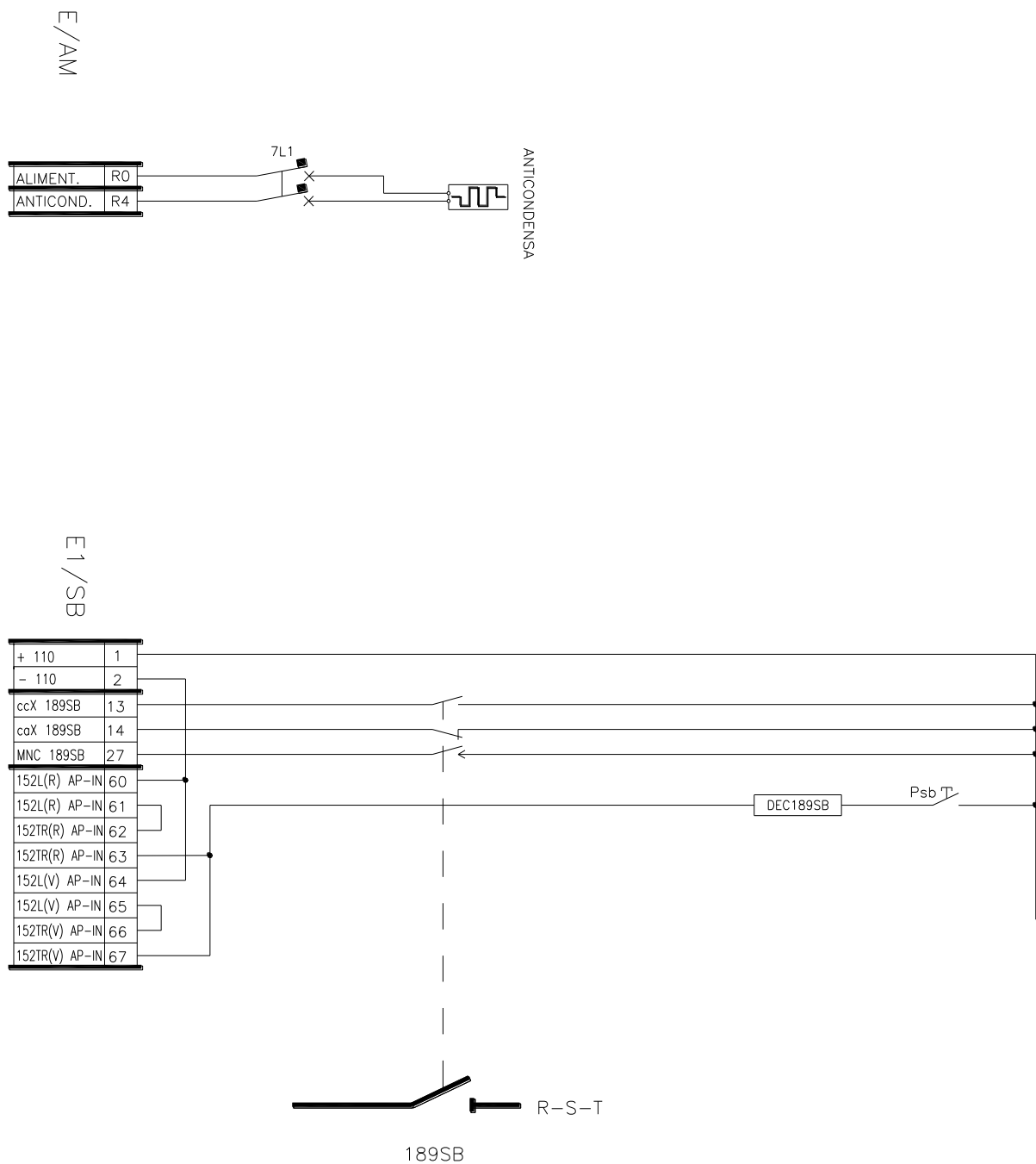

**Application Areas**

Perimeter: Global  
 Staff Function: -  
 Service Function: -  
 Business Line: Infrastructure & Networks

Fig. A.2.6 Motor operated Bus Bar DS (line bay)

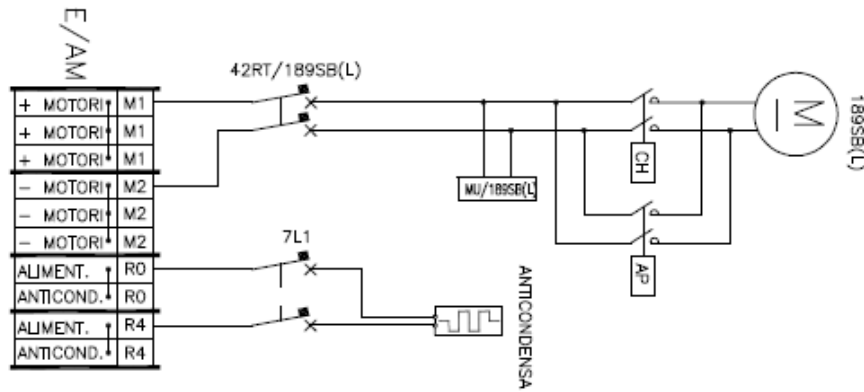

Lo schema è rappresentato con sezionatore aperto e in assenza di tensione

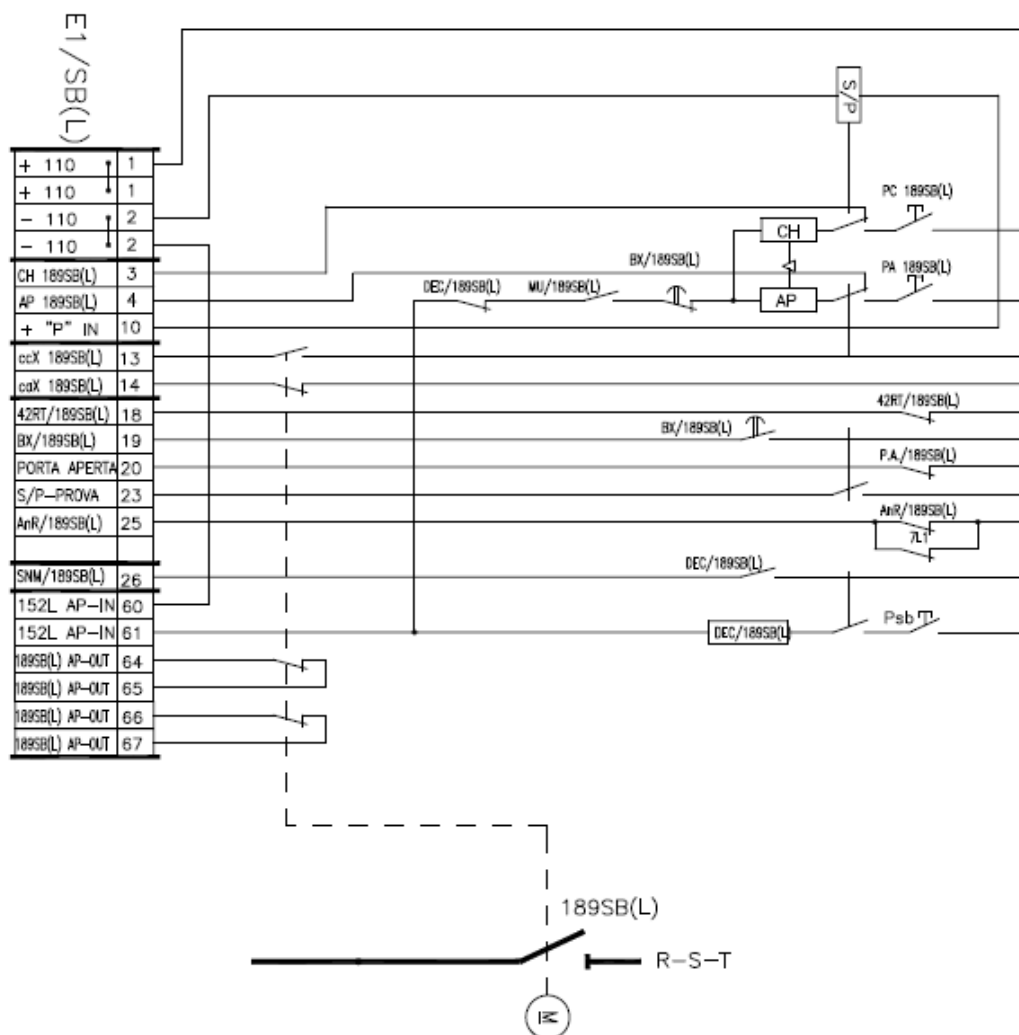
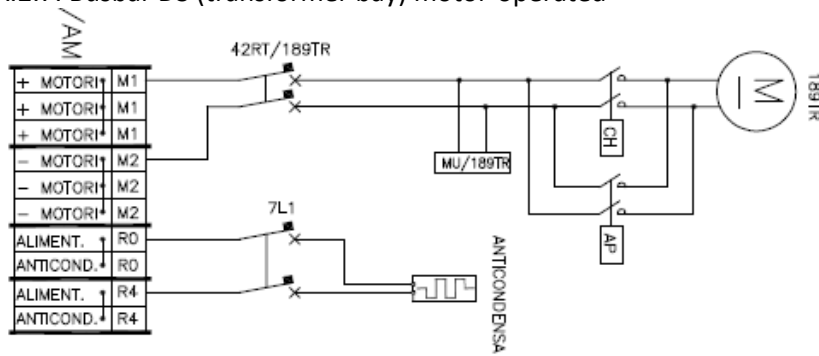

Fig. A.2.6 - SEZIONATORE DI LINEA LATO SIARRA MOTORIZZATO

**Application Areas**

Perimeter: *Global*  
 Staff Function: -  
 Service Function: -  
 Business Line: *Infrastructure & Networks*

Fig A.2.7. Busbar DS (transformer bay) motor-operated



Lo schema e' rappresentato con sezionatore aperto e in assenza di tensione

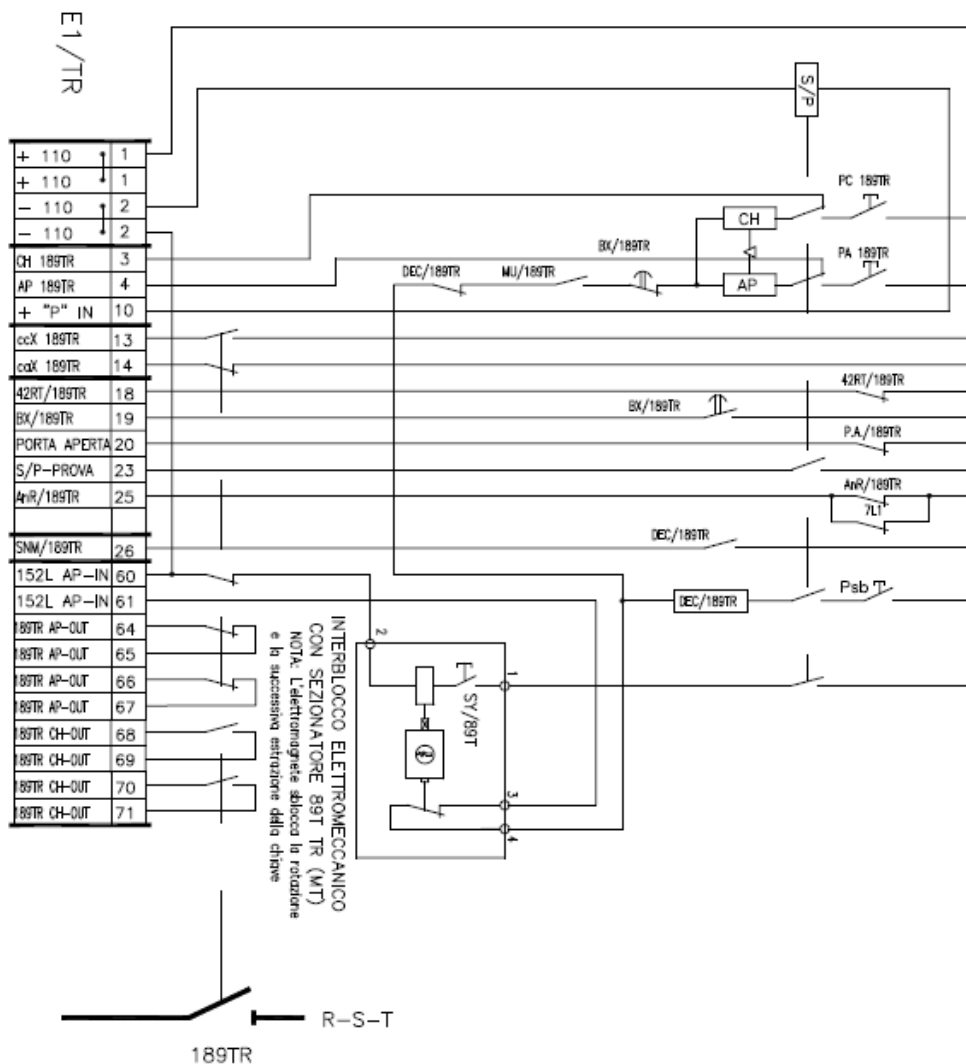

Fig. A.2.7 - SEZIONATORE SBARRA STALLO TRASFORMATORE MOTORIZZATO

**Application Areas**

Perimeter: *Global*

Staff Function: -

Service Function: -

Business Line: *Infrastructure & Networks*

Fig. A.2.8. Conjoint busbar DS motor-operated

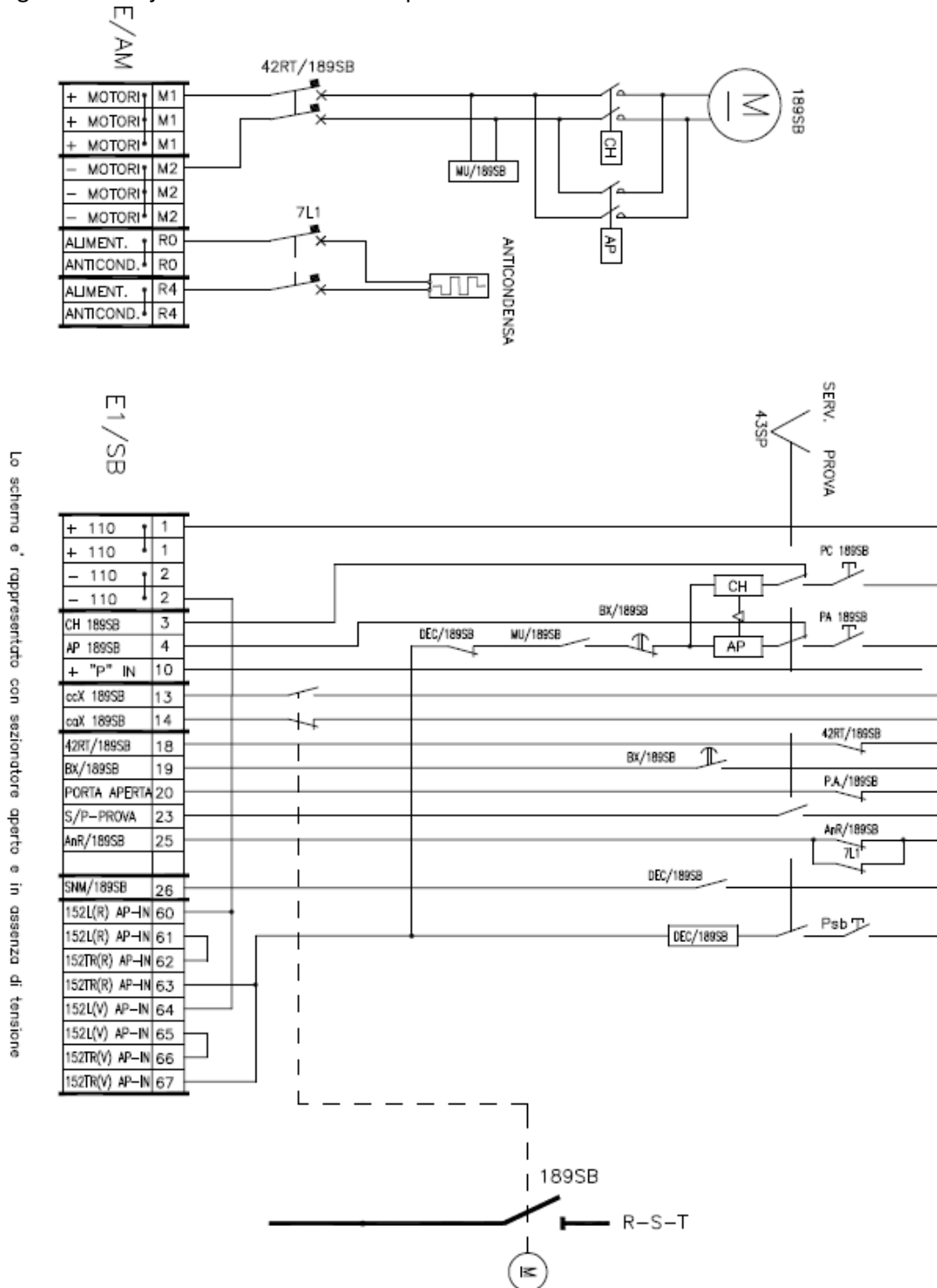

Fig. A.2.8 - SEZIONATORE CONGIUNTORE SBARRA MOTORIZZATO

**Application Areas**

Perimeter: *Global*

Staff Function: -

Service Function: -

Business Line: *Infrastructure & Networks*

Fig. A.2.9. VTs connection

Lo schema è rappresentato con interruttori aperti, pressione gas di valori nominali e in assenza di tensione

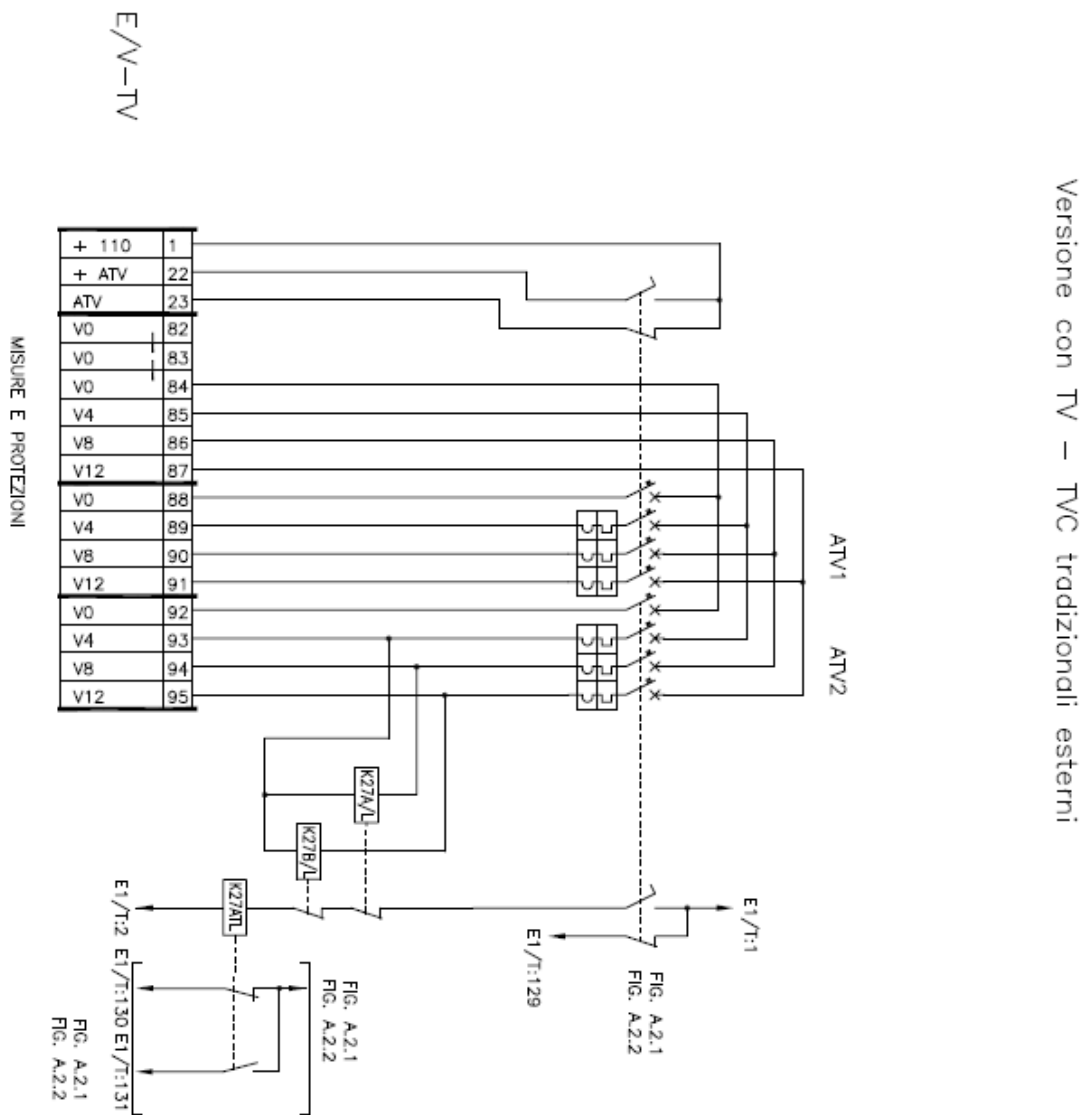

Fig. A.2.9 – COLLEGAMENTO TV



**Application Areas**

 Perimeter: *Global*

Staff Function: -

Service Function: -

 Business Line: *Infrastructure & Networks*
**ANNEX B – DIMENSIONAL DRAWINGS**
**B.1 DISTANCES**

The typical distances are the following (referential)

Different solutions shall be approved by Enel Distribution companies:

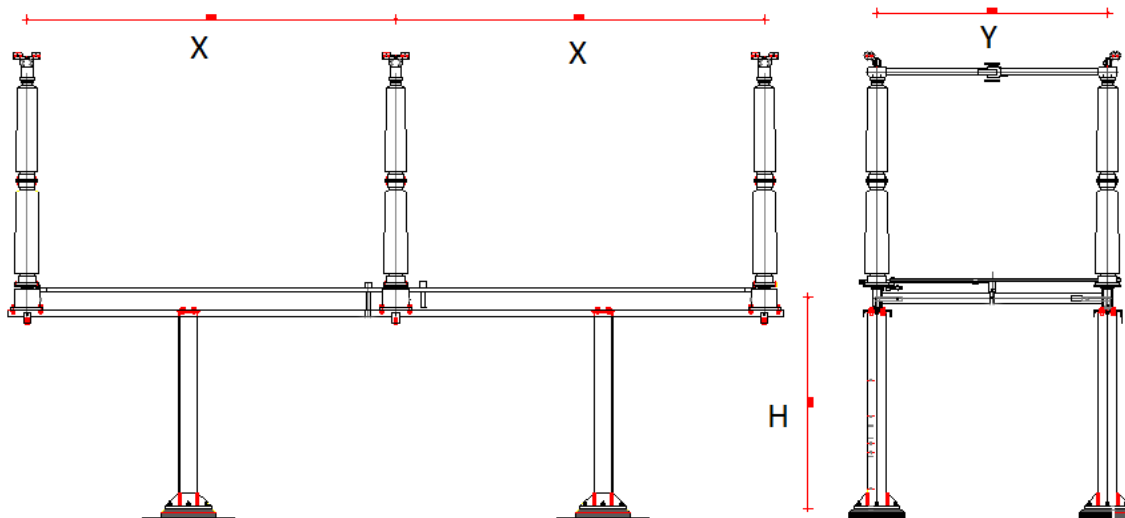

Voltage	X	H
72,5	1500 or 2000	3000
123	2000	2300 (bus bar)/3200 (line)
145	3000	3000
170	2200	2650/5150
245	4000	5150

*Adaptar a Chile, colombia i brasil*

**Application Areas**

Perimeter: *Global*

Staff Function: -

Service Function: -

Business Line: *Infrastructure & Networks*

**B.2 – STANDARD SUPPORT**

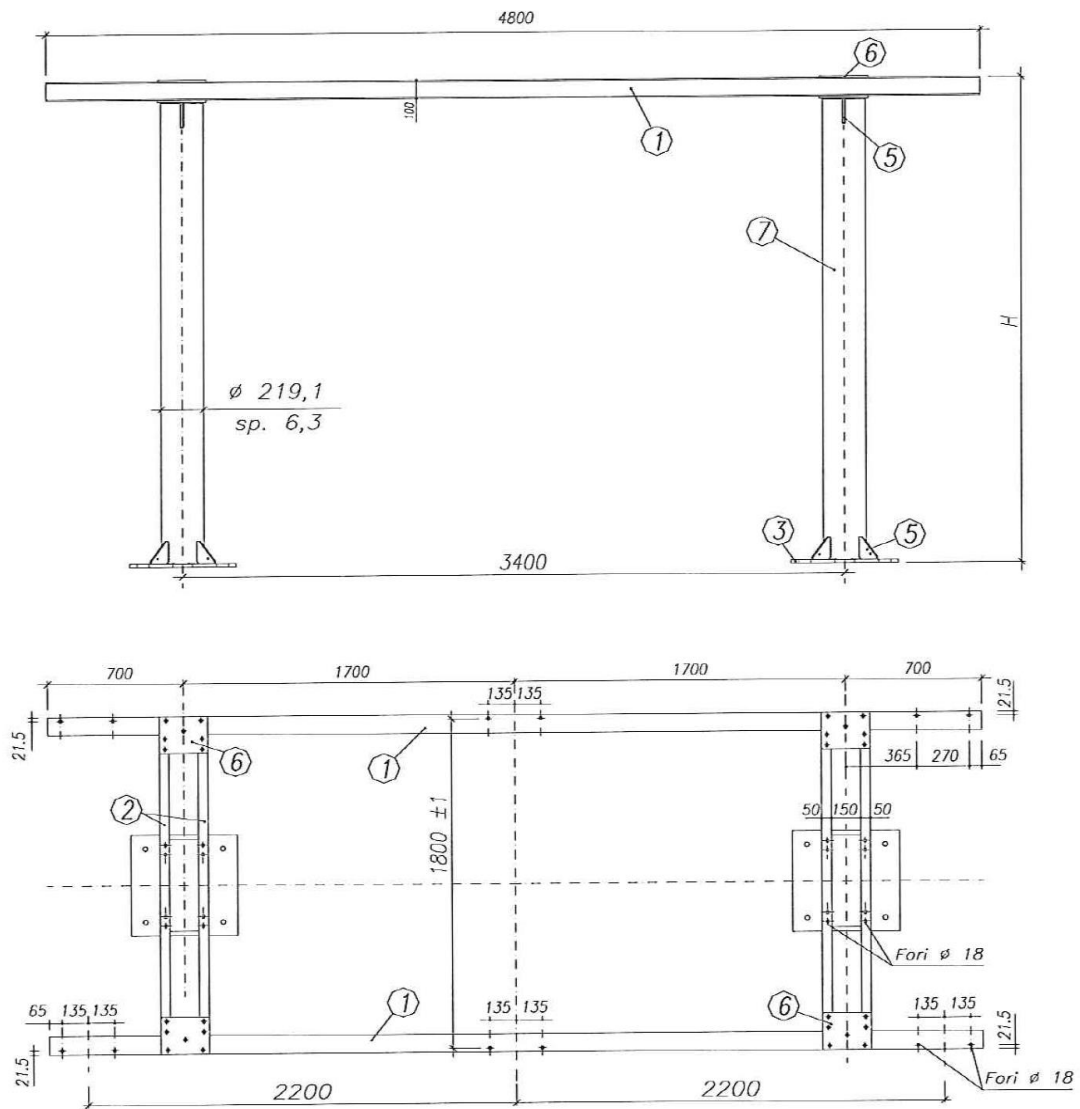

**Application Areas**

Perimeter: *Global*

Staff Function: -

Service Function: -

Business Line: *Infrastructure & Networks*

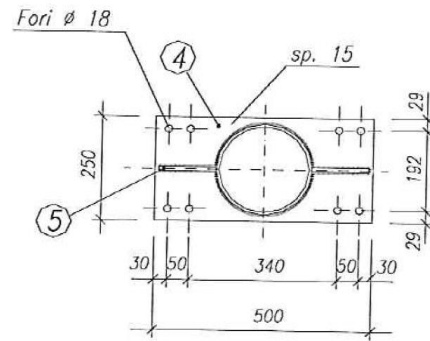
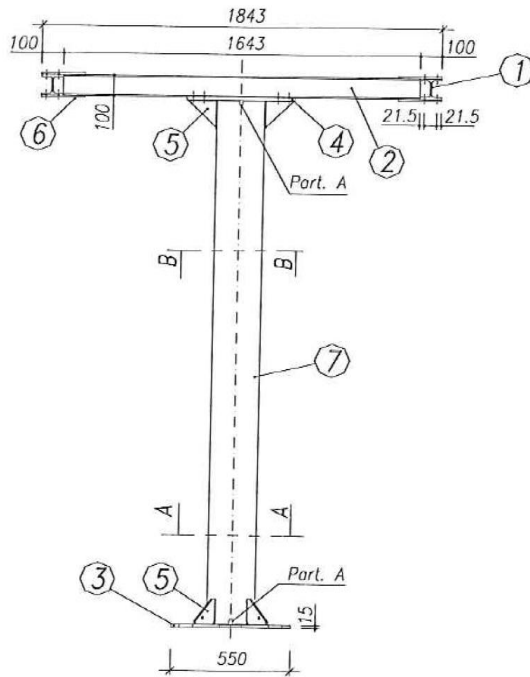

Sez. B-B

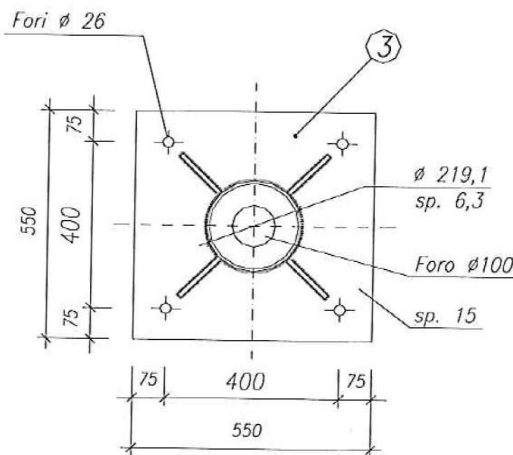
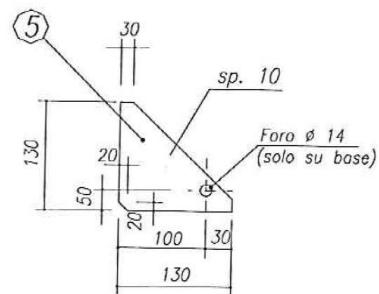

Sez. A-A

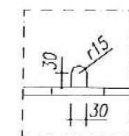
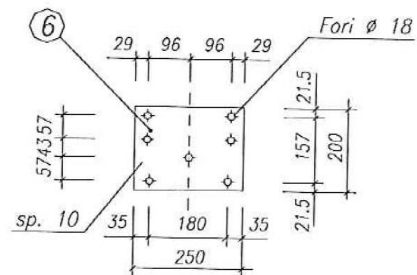

Part. A



**Application Areas**

Perimeter: *Global*

Staff Function: -

Service Function: -

Business Line: *Infrastructure & Networks*

**MONOPOLAR DS FOR NEUTRAL POWER TRANSFORMER**

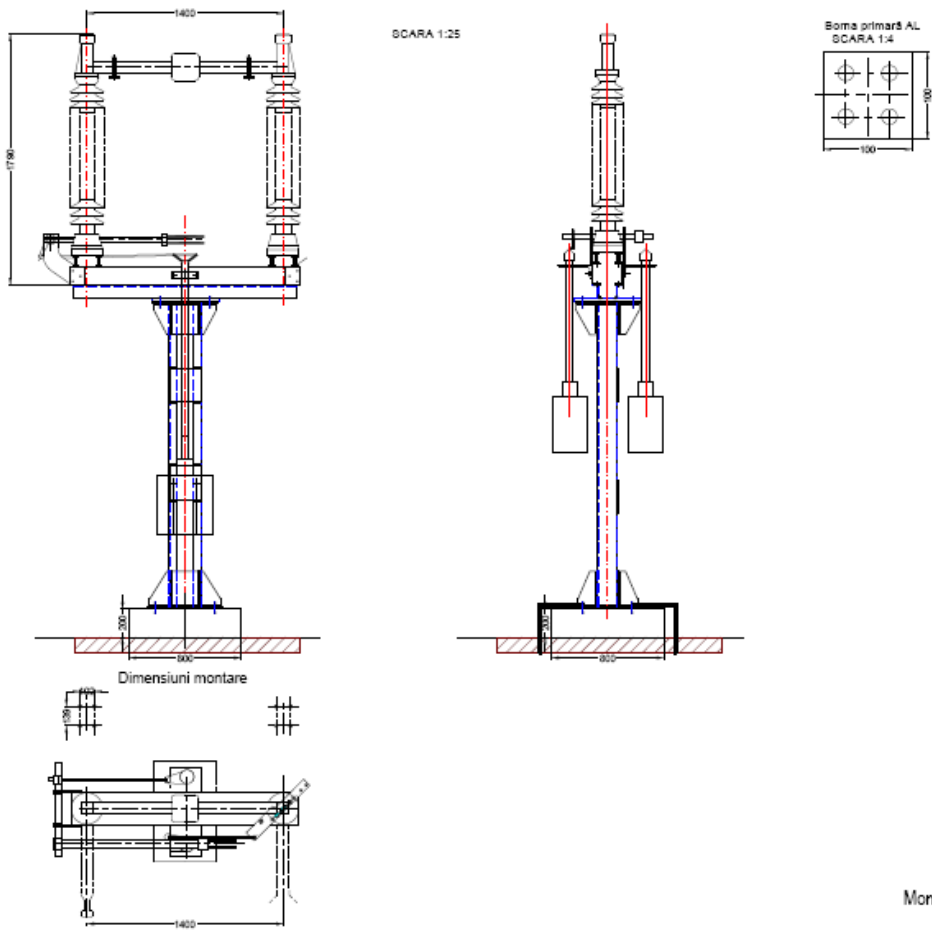

**Application Areas**

Perimeter: *Global*

Staff Function: -

Service Function: -

Business Line: *Infrastructure & Networks*

**B.3 – E-DISTRIBUZIONE DIMENSIONAL DRAWINGS**

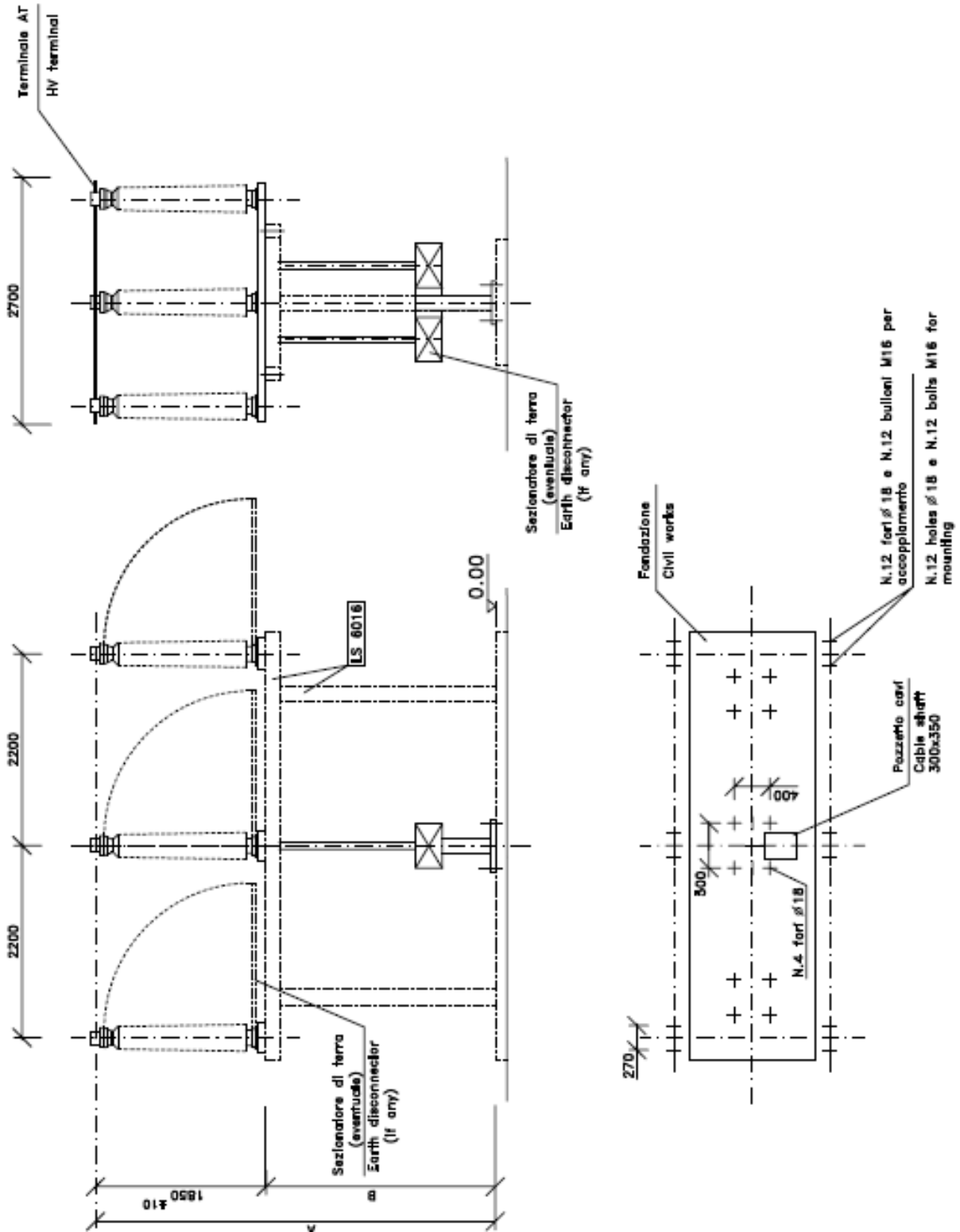

**Application Areas**

 Perimeter: *Global*

Staff Function: -

Service Function: -

 Business Line: *Infrastructure & Networks*
**ANNEX C – TENDER’S TECHNICAL DOCUMENTATION**

<b>GLOBAL STANDARD:</b> GSCH003 – HV DS/ESs		<b>TENDER:</b>	
<b>SUPPLIER:</b>		<b>FACTORY:</b>	
<b>ENEL GROUP TYPE CODE:</b> GSCH003/___		<b>SUPPLIER MODEL:</b>	
<b>TECHNICAL CHARACTERISTIC</b>		<b>STANDARD REQUIREMENT</b>	<b>SUPPLIER OFFER</b>
<i>Service conditions</i>		outdoor normal service conditions of IEC 62271-1	
<i>Reference altitude (m)</i>		< 1.000 (2.600 for Colombia)	
<i>Minimum ambient air temperature (°C)</i>		See Annex D	
<i>SPS Class (IEC/TS 60815 series)</i>		See Annex D	
<i>Ice coating (mm)</i>		See Annex D	
<i>Seismic qualification level</i>		See table in 7.2.2.2	
<i>Rated short-time withstand current I<sub>k</sub> (kA)</i>		See Annex D	
<i>Rated short-duration powerfrequency withstand voltage U<sub>d</sub> (kV rms)</i>	<i>Common value</i>	See table in 5	
	<i>Across the isolating distance</i>	See table in 5	
<i>Rated lightning impulse withstand voltage U<sub>p</sub> (kVp)</i>	<i>Common value</i>	See table in 5	
	<i>Across the isolating distance</i>	See table in 5	
<i>Rated frequency f<sub>r</sub> (Hz)</i>		50 or 60	
<i>Opening (closing) time if motor-operated (s)</i>	<i>DS</i>	≤ 15	
	<i>ES</i>	≤ 15	
<i>Degrees of protection provided by enclosures</i>		IP 54	
<i>Rated supply voltage U<sub>a</sub> (Vdc)</i>		See table in 5	
<i>d.c. max absorbed power (W)</i>		1.000	
<i>Rated supply voltage for heating and anti-condensation circuits (Vac)</i>		See table in 5	
<i>a.c. max absorbed power (VA)</i>		50 (250 if motor-operated)	
<i>Auxiliary contact classes</i>		1	
<i>DS Rated normal current I<sub>r</sub> (A)</i>		See Annex D	
<i>DS Mechanical endurance class M<sub>r</sub></i>		M1	
<i>Bus-transfer current switching by disconnectors</i>	<i>Rated bus-transfer current for disconnectors (A)</i>	See Annex D and table in 5	
	<i>Rated bus-transfer voltages for disconnectors (V)</i>	See Annex D and table in 5	
<i>Earthing switches class E<sub>r</sub></i>		E0 – M0 – A	
<i>Insulators materials</i>		Composite	
<i>Dimensions</i>			To enclose an overall equipment drawing for each Enel Group Distribution Company



Application Areas

Perimeter: Global

Staff Function: -

Service Function: -

Business Line: Infrastructure & Networks

ANNEX D – COMPONENT LIST

TYPE CODE	COMPANY	COMPANY CODE	E4E CODE	CODE	DESCRIPCION	Nº Columns/pole	Type opening	Ur	lr	lk	ES	DS operation	ES operation	SPS class	Bus bar transfer	Minimum ambient air temperature (°C)	Ice coating (mm)	ASSEMBLY	Installation height (mm)
GSH003/200	EDE	6701206	140024	140621	SECCION. III,72,5KV,EXT,2000A,CON PAT MM POL	2	Central break	72,5	2000	31,5	Y	MANUAL	MANUAL	d	N	-25	10	Horizontal paralel	3000 mm
GSH003/201	EDE	6701207	140025	140620	SECCION. III,72,5KV,EXT,2000A, SIN PAT MM POL	2	Central break	72,5	2000	31,5	N	MANUAL	-	d	N	-25	10	Horizontal paralel	3000 mm
GSH003/202	EDE	6701208	140026	140619	SECCION. III,72,5KV,EXT,1250A,CON PAT MM POL	2	Central break	72,5	1250	31,5	Y	MANUAL	MANUAL	d	N	-25	10	Horizontal paralel	3000 mm
GSH003/203	EDE	6701209	140027	140618	SECCION. III,72,5KV,EXT,1250A, SIN PAT MM POL	2	Central break	72,5	1250	31,5	N	MANUAL	-	d	N	-25	10	Horizontal paralel	3000 mm
GSH003/204	EDE	6707698	150056	140622	SEC 72,5KV 2000A 31,5KA E MM PAT LF 31MM POL	2	Central break	72,5	2000	31,5	Y	MANUAL	MANUAL	e	N	-25	10	Horizontal paralel	3000 mm
GSH003/205	EDE	6707699	150057	140617	SEC72,5KV 2000A 31,5KA E MM SIN PAT LF31 POL	2	Central break	72,5	2000	31,5	N	MANUAL	-	e	N	-25	10	Horizontal paralel	3000 mm
GSH003/206	EDE	6707700	150058	150033	SEC 72,5KV 1250A 31,5KA E MM PAT LF 31MM POL	2	Central break	72,5	1250	31,5	Y	MANUAL	MANUAL	e	N	-25	10	Horizontal paralel	3000 mm
GSH003/207	EDE	6707701	150059	150003	SEC72,5K 1250A 31,5KA E MM SIN PAT LF 31 POL	2	Central break	72,5	1250	31,5	N	MANUAL	-	e	N	-25	10	Horizontal paralel	3000 mm
GSH003/208	EDE	6701204	150049	150174	SECCION. III,145KV,EXT,1250A, CON PAT MM POL	2	Central break	145	1250	31,5	N	MANUAL	-	d	N	-25	10	Horizontal paralel	3000 mm
GSH003/209	EDE	6707696	150054	150165	SEC 145KV 1250A 31,5KA E MM PAT LF31MM-K POL	2	Central break	145	1250	31,5	N	MANUAL	-	e	N	-25	10	Horizontal paralel	3000 mm
GSH003/210	EDE	6701205	150170	150040	SECCION. III,145KV,EXT,1250A, SIN PAT MM POL	2	Central break	145	1250	31,5	Y	MANUAL	MANUAL	d	N	-25	10	Horizontal paralel	3000 mm
GSH003/211	EDE	6707697	150055	150175	SEC145KV 1250A 31,5KA E MM SIN PAT LF31M POL	2	Central break	145	1250	31,5	Y	MANUAL	MANUAL	e	N	-25	10	Horizontal paralel	3000 mm
GSH003/212	EDE	6710771	140036	140624	SEC 145KV 1250A 31,5KA E ME SIN PAT LF25 POL	2	Central break	145	1250	31,5	N	MOTOR	-	d	N	-25	10	Horizontal paralel	3000 mm
GSH003/213	EDE	6710772	140037	140623	SEC 145KV 1250A 31,5KA E ME SIN PAT LF31 POL	2	Central break	145	1250	31,5	N	MOTOR	-	e	N	-25	10	Horizontal paralel	3000 mm
GSH003/214	EDE	6710773	140038	140625	SEC 145KV 1250A 31,5KA E ME PAT MM LF25M POL	2	Central break	145	1250	31,5	Y	MOTOR	MANUAL	d	N	-25	10	Horizontal paralel	3000 mm
GSH003/215	EDE	6710774	140039	140626	SEC 145KV 1250A 31,5KA E ME PAT MM LF31M POL	2	Central break	145	1250	31,5	Y	MOTOR	MANUAL	e	N	-25	10	Horizontal paralel	3000 mm
GSH003/216	EDE	6701203	150048	150177	SECCION. III,145KV,EXT,2000A, SIN PAT MM POL	2	Central break	145	2000	31,5	N	MANUAL	-	d	N	-25	10	Horizontal paralel	3000 mm
GSH003/217	EDE	6707695	150053	150215	SEC 145KV 2000A 31,5KA E MM SIN PAT LF31 POL	2	Central break	145	2000	31,5	N	MANUAL	-	e	N	-25	10	Horizontal paralel	3000 mm
GSH003/218	EDE	6701202	150047	150176	SECCION. III,145KV,EXT,2000A, CON PAT MM POL	2	Central break	145	2000	31,5	Y	MANUAL	MANUAL	d	N	-25	10	Horizontal paralel	3000 mm
GSH003/219	EDE	6707694	150052	150179	SEC 145KV 2000A 31,5KA E MM PAT LF31MM-K POL	2	Central break	145	2000	31,5	Y	MANUAL	MANUAL	e	N	-25	10	Horizontal paralel	3000 mm
GSH003/220	EDE	6710775	140220	150178	SEC 145KV 2000A 31,5KA E ME SIN PAT LF25 POL	2	Central break	145	2000	31,5	N	MOTOR	-	d	N	-25	10	Horizontal paralel	3000 mm
GSH003/221	EDE	6710776	140221	150228	SEC 145KV 2000A 31,5KA E ME SIN PAT LF31 POL	2	Central break	145	2000	31,5	N	MOTOR	-	e	N	-25	10	Horizontal paralel	3000 mm
GSH003/222	EDE	6710777	140222	150219	SEC 145KV 2000A 31,5KA E ME PAT MM LF25M POL	2	Central break	145	2000	31,5	Y	MOTOR	MANUAL	d	N	-25	10	Horizontal paralel	3000 mm
GSH003/223	EDE	6710778	140223	150229	SEC 145KV 2000A 31,5KA E ME PAT MM LF31M POL	2	Central break	145	2000	31,5	Y	MOTOR	MANUAL	e	N	-25	10	Horizontal paralel	3000 mm
GSH003/224	EDE			150377	SEC. 52KV2000A31,5KA E MM CON PAT MM POL	2	Central break	52	2000	31,5	Y	MANUAL	MANUAL	e	N	-25	10	Horizontal paralel	3000 mm
GSH003/225	EDE			150378	SEC52KV2000A31,5KA E MM SIN PAT LF31MPOL	2	Central break	52	2000	31,5	N	MANUAL	-	e	N	-25	10	Horizontal paralel	3000 mm
GSH003/226	EDE			150379	SEC52KV1250A31,5KA E MM SIN PAT LF31MPOL	2	Central break	52	1250	31,5	N	MANUAL	-	e	N	-25	10	Horizontal paralel	3000 mm
GSH003/227	EDE			150546	SEC. 52KV1250A31,5KA E MM CON PAT MM POL	2	Central break	52	1250	31,5	Y	MANUAL	MANUAL	e	N	-25	10	Horizontal paralel	3000 mm
GSH003/228	EDE			150547	SEC. 52KV 2000A 31,5KA E MM SIN PAT POL	2	Central break	52	200	31,5	N	MANUAL	-	e	N	-25	10	Horizontal paralel	3000 mm
GSH003/229	EDE			150548	SEC52KV2000A31,5KA E MM CON PAT LF31MPOL	2	Central break	52	2000	31,5	Y	MANUAL	MANUAL	e	N	-25	10	Horizontal paralel	3000 mm
GSH003/230	EDE			150550	SEC52KV1250A31,5KA E MM CON PAT LF31MPOL	2	Central break	52	1250	31,5	Y	MANUAL	MANUAL	e	N	-25	10	Horizontal paralel	3000 mm
GSH003/231	EDE			150551	SEC. 52KV 1250A 31,5KA E MM SIN PAT POL	2	Central break	52	1250	31,5	N	MANUAL	-	e	N	-25	10	Horizontal paralel	3000 mm



TYPE CODE	COMPANY	CODE	DESCRIPCION	N° Columns/pol e	Type opening	Ur	lr	lk	ES	DS operation	ES operation	SPS class	Bus bar transfer	Minimum ambient air temperature (°C)	Ice coating (mm)	ASSEMBLY	Installation height (mm)
GSH003/001	e-distribuzione	156110	SEZ.+SEZ.TERRA LINEA MOTORIZZ.145-170 k	3	Double break	170	1250	31.5	Y	MOTOR	MOTOR	d	N	-25	10	Horizontal paralel	2650 mm
GSH003/002	e-distribuzione	156111	SEZ.+SEZ.TERRA LINEA MANUALE 145-170 kV	3	Double break	170	1250	31.5	Y	MANUAL	MANUAL	d	N	-25	10	Horizontal paralel	2650 mm
GSH003/003	e-distribuzione	156112	SEZ. SBARRA LINEA MANUALE 145-170 kV	3	Double break	170	1250	31.5	N	MANUAL	-	d	N	-25	10	Horizontal paralel	2650 mm
GSH003/004	e-distribuzione	156113	SEZ. SBARRA TRASFORM. MANUALE 145-170 k.	3	Double break	170	1250	31.5	N	MANUAL	-	d	N	-25	10	Horizontal paralel	2650 mm
GSH003/005	e-distribuzione	156114	SEZ. CONGIUNT. SBARRA MANUALE 145-170 k.	3	Double break	170	1250	31.5	N	MANUAL	-	d	N	-25	10	Horizontal paralel	5150 mm
GSH003/006	e-distribuzione	150003	Sez. AT sbarra linea motoriz.	3	Double break	170	1250	31.5	N	MOTOR	-	d	N	-25	10	Horizontal paralel	2650 mm
GSH003/007	e-distribuzione	150004	Sez. AT sbarra trasf. motor.	3	Double break	170	1250	31.5	N	MOTOR	-	d	N	-25	10	Horizontal paralel	2650 mm
GSH003/008	e-distribuzione	150005	Sez. AT congiuntore sb. motor.	3	Double break	170	1250	31.5	N	MOTOR	-	d	N	-25	10	Horizontal paralel	5150 mm
GSH003/009	e-distribuzione	156850	SOST SEZ O3P150 2,2 H2,65 LS6016/1 UE	-	Support	170	-	-	-	-	-	-	-	-	-	Horizontal paralel	2650 mm
GSH003/010	e-distribuzione	156852	SOST SEZ O3P150 2,2 H5,15 LS6016/3 UE	-	Support	170	-	-	-	-	-	-	-	-	-	Horizontal paralel	5150 mm



Application Areas

Perimeter: Global

Staff Function: -

Service Function: -

Business Line: Infrastructure & Networks

TYPE CODE	COMPANY	OLD CODE	E4E CODE	DESCRIPCION	Nº Columns/pol e	Type opening	Ur	lr	lk	ES	DS operation	ES operation	SPS class	Bus bar transf	Minimum ambient air temperatur	Ice coating (mm)	ASSEMBLY	Installation height (m)
GSCH003/900	E-RIO	4545883	150697	CH,72KV,1250A,MAN,C/LT,VER,<10m,GSCH003	2	Central break	72,5	1250	25	Y	MANUAL	MANUAL	d	N	-10	1	Vertical	< 10000
GSCH003/901	E-RIO	4545884	150698	CH,72KV,1250A,MAN,C/LT,HOR,<6m,GSCH003	2	Central break	72,5	1250	25	Y	MANUAL	MANUAL	d	N	-10	1	Horizontal paralel	< 6000
GSCH003/902	E-RIO	4545894	150705	CH,72KV,1250A,MAN,C/LT,HOR,>10m,GSCH003	2	Central break	72,5	1250	25	Y	MANUAL	MANUAL	d	N	-10	1	Horizontal paralel	> 10000
GSCH003/903	E-RIO	4545875	150695	CH,72KV,1250A,MAN,S/LT,HOR,>10m,GSCH003	2	Central break	72,5	1250	25	N	MANUAL	-	d	N	-10	1	Horizontal paralel	> 10000
GSCH003/904	E-RIO	4545893	150704	CH,72KV,1250A,MAN,S/LT,VER,<10m,GSCH003	2	Central break	72,5	1250	25	N	MANUAL	-	d	N	-10	1	Vertical	< 10000
GSCH003/905	E-RIO	4545888	150701	CH72,5KV-1250A MAN S/LT MONT HOR <6,0M	2	Central break	72,5	1250	25	N	MANUAL	-	d	N	-10	1	Horizontal paralel	< 6000
GSCH003/906	E-RIO	4545891	150941	CH,72KV,1250A,MOT,C/LT,HOR,<6m,GSCH003	2	Central break	72,5	1250	25	Y	MOTOR	MANUAL	d	N	-10	1	Horizontal paralel	< 6000
GSCH003/907	E-RIO	4545890	150703	CH,72KV,1250A,MAN,S/LT,HOR,<10m,GSCH003	2	Central break	72,5	1250	25	N	MANUAL	-	d	N	-10	1	Horizontal paralel	< 10000
GSCH003/908	E-RIO	4545882	150696	CH,72KV,1250A,MOT,C/LT,HOR,>10m,GSCH003	2	Central break	72,5	1250	25	Y	MOTOR	MANUAL	d	N	-10	1	Horizontal paralel	> 10000
GSCH003/909	E-RIO	4545889	150702	CH,72KV,1250A,MOT,S/LT,HOR,<6m,GSCH003	2	Central break	72,5	1250	25	N	MOTOR	-	d	N	-10	1	Horizontal paralel	< 6000
GSCH003/910	E-RIO	4545917	150713	CH,72KV,1250A,MOT,S/LT,HOR,<10m,GSCH003	2	Central break	72,5	1250	25	N	MOTOR	-	d	N	-10	1	Horizontal paralel	< 10000
GSCH003/911	E-RIO	4545886	150699	CH,72KV,1250A,MOT,S/LT,HOR,>10m,GSCH003	2	Central break	72,5	1250	25	N	MOTOR	-	d	N	-10	1	Horizontal paralel	> 10000
GSCH003/912	E-RIO	4545872	150693	CH,145KV,1250A,MAN,C/LT,HOR,<10m,GSCH003	2	Central break	145	1250	40	Y	MANUAL	MANUAL	d	N	-10	1	Horizontal paralel	< 10000
GSCH003/913	E-RIO	4545887	150700	CH,145KV,1250A,MAN,C/LT,VER,<10m,GSCH003	2	Central break	145	1250	40	Y	MANUAL	MANUAL	d	N	-10	1	Vertical	< 10000
GSCH003/914	E-RIO	4545869	150940	CH,145KV,1250A,MAN,C/LT,HOR,>10m,GSCH003	2	Central break	145	1250	40	Y	MANUAL	MANUAL	d	N	-10	1	Horizontal paralel	> 10000
GSCH003/915	E-RIO	4545868	150692	CH145KV-1250A MAN S/LT MONT HOR <6,0M	2	Central break	145	1250	40	N	MANUAL	-	d	N	-10	1	Horizontal paralel	< 6000
GSCH003/916	E-RIO	4545916	150712	CH,72KV,1250A,MAN,S/LT,HOR,<10m,GSCH003	2	Central break	72,5	1250	25	N	MANUAL	-	d	N	-10	1	Horizontal paralel	< 10000
GSCH003/917	E-RIO	4545948	150716	CH145KV-1250A MAN S/LT MONT VERT <10,0M	2	Central break	145	1250	40	N	MANUAL	-	d	N	-10	1	Vertical	< 10000
GSCH003/918	E-RIO	4545960	150718	CH,145KV,1250A,MOT,C/LT,HOR,<6m,GSCH003	2	Central break	145	1250	40	Y	MOTOR	MANUAL	d	N	-10	1	Horizontal paralel	< 6000
GSCH003/919	E-RIO	4545961	150942	CH,145KV,1250A,MOT,S/LT,HOR,<10m,GSCH003	2	Central break	145	1250	40	N	MOTOR	-	d	N	-10	1	Horizontal paralel	< 10000
GSCH003/920	E-RIO	4545955	150717	CH,145KV,1250A,MOT,C/LT,HOR,<10m,GSCH003	2	Central break	145	1250	40	Y	MOTOR	MANUAL	d	N	-10	1	Horizontal paralel	>10000
GSCH003/921	E-RIO	4584354	150721	CH,145KV,1250A,MOT,S/LT,HOR,<6m,GSCH003	2	Central break	145	1250	40	N	MOTOR	-	d	N	-10	1	Horizontal paralel	< 6000
GSCH003/922	E-RIO	4545855	150691	CH,145KV,1250A,MOT,S/LT,VER,<10m,GSCH003	2	Central break	145	1250	40	N	MOTOR	-	d	N	-10	1	Vertical	< 10000
GSCH003/923	E-RIO	4545874	150694	CH145KV-1250A MAN S/LT MONT HOR >10,0M	2	Central break	145	1250	40	N	MANUAL	-	d	N	-10	1	Horizontal paralel	> 10000
GSCH003/924	E-RIO	6806423	150767	CH,72KV,1250A,MOT,S/LT,VER,<10m,GSCH003	2	Central break	72,5	1250	25	N	MOTOR	-	d	N	-10	1	Vertical	< 10000
GSCH003/925	E-RIO	6806426	150954	CH,72KV,1250A,MAN,S/LT,VER,>10m,GSCH003	2	Central break	72,5	1250	25	N	MANUAL	-	d	N	-10	1	Vertical	> 10000
GSCH003/926	E-RIO	6806427	150768	CH,145KV,1250A,MAN,S/LT,VER,>10m,GSCH003	2	Central break	145	1250	40	N	MANUAL	-	d	N	-10	1	Vertical	> 10000
GSCH003/927	E-RIO	6808300	150769	CH145KV-1250A-MOT-C/LT-TRIP-CENTRAL->10M	2	Central break	145	1250	40	Y	MOTOR	MANUAL	d	N	-10	1	Vertical Invertida	> 10000
GSCH003/928	E-RIO	6810930	150770	CHAVE, SECC,LT,145KV,2000A,3F,MAN,SECO	2	Central break	145	2000	40	Y	MANUAL	MANUAL	d	N	-10	1	Vertical	< 10000
GSCH003/929	E-RIO	6810931	150771	CHAVE, SECC,145KV,2000A,3F,MAN,SECO,<10M	2	Central break	145	2000	40	N	MANUAL	-	d	N	-10	1	Vertical	< 10000
GSCH003/930	E-RIO	6810932	150772	CH,SEC,145KV,2000A,3F,MAN,SECO,GSCH003	2	Central break	145	2000	40	N	MANUAL	-	d	N	-10	1	Vertical	> 10000
GSCH003/931	E-RIO	6816305	6816305	SEC,72,5KV,1250A,TRIP,MA,SECO,GSCH003/931	2	Lateral break	72,5	1250	31,5	N	MANUAL	-	d	N	-10	1	Vertical	> 10000
GSCH003/932	E-RIO	T150040	150807	CH,SEC,145KV,2000A,3F,MAN,SECO,GSCH003	2	Central break	145	2000	40	N	MANUAL	-	d	N	-10	1	Horizontal paralel	> 10000
GSCH003/933	E-RIO	T150007	150805	CH,145KV,2000A,MAN,C/LT,HOR,<10m,GSCH003	2	Central break	145	2000	40	Y	MANUAL	MANUAL	d	N	-10	1	Horizontal paralel	< 10000
GSCH003/934	E-RIO	T150008	150806	CH,145KV,2000A,MAN,S/LT,HOR,<10m,GSCH003	2	Central break	145	2000	40	N	MANUAL	-	d	N	-10	1	Horizontal paralel	< 10000
GSCH003/935	E-RIO	990208	990208	CH,145KV,2000A,MAN,C/LT,VERT,<10m,GSCH003	3	Double-Break	145	2000	40	Y	Manual	Manual	d	N	-10	1	Vertical	< 10000
GSCH003/936	E-RIO	990209	990209	CH,145KV,4000A,MAN,C/LT,VERT,<10m,GSCH003	3	Double-Break	145	4000	40	Y	Manual	Manual	d	N	-10	1	Vertical	< 10000
GSCH003/937	E-RIO	990215	990215	CH,145KV,2000A,MAN,S/LT,HOR,>10m,GSCH003	3	Double-Break	145	2000	40	N	Manual	-	d	N	-10	1	Horizontal	> 10000
GSCH003/938	E-RIO	150970	150970	CH,145KV,4000A,MAN,S/LT,HOR,>10m,GSCH003	3	Double-Break	145	4000	40	N	Manual	-	d	N	-10	1	Horizontal	> 10000
GSCH003/939	E-RIO	990210	990210	CH,145KV,2000A,MOT,S/LT,VERT,<10m,GSCH003	3	Double-Break	145	2000	40	N	Motor	-	d	N	-10	1	Vertical	< 10000
GSCH003/940	E-RIO	990211	990211	CH,145KV,4000A,MOT,S/LT,VERT,<10m,GSCH003	3	Double-Break	145	4000	40	N	Motor	-	d	N	-10	1	Vertical	< 10000
GSCH003/941	E-RIO	990214	990214	CH,145KV,2000A,MOT,S/LT,HOR,<6m,GSCH003	3	Double-Break	145	2000	40	N	Motor	-	d	N	-10	1	Horizontal	< 6000
GSCH003/942	E-RIO	990213	990213	CH,145KV,4000A,MOT,S/LT,HOR,<6m,GSCH003	3	Double-Break	145	4000	40	N	Motor	-	d	N	-10	1	Horizontal	< 6000
GSCH003/943	E-RIO	*	150971	CH,145KV,2000A,MOT,S/LT,HOR,<10m,GSCH003	3	Double-Break	145	2000	40	N	Motor	-	d	N	-10	1	Horizontal	<6000
GSCH003/944	E-RIO	*	990216	CH,145KV,2000A,MOT,S/LT,HOR,>10m,GSCH003	3	Double-Break	145	2000	40	N	Motor	-	d	N	-10	1	Horizontal	>10000
GSCH003/945	E-RIO	*	990212	CH,145KV,2000A,MOT,C/LT,HOR,<6m,GSCH003	3	Double-Break	145	2000	40	Y	Motor	Manual	d	N	-10	1	Horizontal	< 6000
GSCH003/946	E-RIO	150093	150093	CH,145KV,2000A,MOT,C/LT,HOR<6m,GSCH003	3	Double-Break	145	2000	40	Y	Motor	Manual	d	N	-10	1	Horizontal paralel	< 6000
GSCH003/947	E-RIO	150092	150092	CH,72KV,1250A,MAN,C/LT,HOR<6m,GSCH003	2	Central-Break	72,5	1250	31.5	N	Motor	-	d	N	-10	1	Horizontal paralel	< 6000
GSCH003/948	E-RIO	150091	150091	CH72,5KV,1250A,MAN,S/LT,HOR<6m,GSCH003	2	Central-Break	72,5	1250	31.5	N	Manual	-	d	N	-10	1	Horizontal paralel	< 6000

\* Vdc is 220 V



Technical Specification code: MAT-O&M-NCS-2021-00XX-EGIN

Version no. 4 dated 19.09.2021

Subject: Global infrastructure and Networks GSCH003 HV DISCONNECTORS WITH RATED VOLTAGE 72,5KV TO 245 kV

Application Areas

Perimeter: Global

Staff Function: -

Service Function: -

Business Line: Infrastructure & Networks

TYPE CODE	COMPANY	COMPANY CODE	E4E CODE	CODE	DESCRICION	Nº Columns/pole	Type opening	Ur	Ir	Ik	ES	DS operation	ES operation	SPS class	Bus bar transfer	Minimum ambient air temperature	Ice coating (mm)	ASSEMBLY	Installation height (mm)
GSH003/600	E-CEARÁ	4544141	4544141	150686	SECCIONADOR, TRIPOLAR, 72.5KV, 1250A, COMANDO MANUAL, COM LAMINA DE TERRA, ABERTURA CENTRAL MONTAGEM HORIZONTAL PARALELA	2	Central break	73	1250	32	Y	MANUAL	MANUAL	e	N	-10	1	Horizontal paralel	10010mm
GSH003/601	E-CEARÁ	6771461	6771461	150742	SECCIONADOR, TRIPOLAR, 72.5KV, 1250A, COMANDO MANUAL, SEM LAMINA DE TERRA, ABERTURA CENTRAL MONTAGEM HORIZONTAL PARALELA	2	Central break	73	1250	32	N	MANUAL	-	e	N	-10	1	Horizontal paralel	10010mm
GSH003/602	E-CEARÁ	6771466	6771466	150745	SECCIONADOR, TRIPOLAR, 72.5KV, 2000A, COMANDO MANUAL, COM LAMINA DE TERRA, ABERTURA CENTRAL MONTAGEM HORIZONTAL PARALELA	2	Central break	73	2000	32	Y	MANUAL	MANUAL	e	N	-10	1	Horizontal paralel	10010mm
GSH003/603	E-CEARÁ	6771467	6771467	150746	SECCIONADOR, TRIPOLAR, 72.5KV, 2000A, COMANDO MANUAL, SEM LAMINA DE TERRA, ABERTURA CENTRAL MONTAGEM HORIZONTAL PARALELA	2	Central break	73	2000	32	N	MANUAL	-	e	N	-10	1	Horizontal paralel	10010mm
GSH003/604	E-CEARÁ	6771465	6771465	150744	SECCIONADOR, TRIPOLAR, 72.5KV, 1250A, COMANDO MANUAL, SEM LAMINA DE TERRA, ABERTURA CENTRAL MONTAGEM VERTICAL ALTA ALTURA DA	2	Central break	73	1250	32	N	MANUAL	-	e	N	-10	1	Vertical	6000mm
GSH003/605	E-CEARÁ	6771469	6771469	150748	SECCIONADOR, TRIPOLAR, 72.5KV, 2000A, COMANDO MANUAL, SEM LAMINA DE TERRA, ABERTURA CENTRAL MONTAGEM VERTICAL ALTA ALTURA DA	2	Central break	73	2000	32	N	MANUAL	-	e	N	-10	1	Vertical	6000mm
GSH003/606	E-CEARÁ	6771462	6771462	150743	SECCIONADOR, TRIPOLAR, 72.5KV, 1250A, COMANDO MANUAL, SEM LAMINA DE TERRA, ABERTURA CENTRAL MONTAGEM HORIZONTAL PARALELA	2	Central break	73	1250	32	N	MANUAL	-	e	N	-10	1	Horizontal paralel	2470mm
GSH003/607	E-CEARÁ	6771468	6771468	150747	SECCIONADOR, TRIPOLAR, 72.5KV, 2000A, COMANDO MANUAL, SEM LAMINA DE TERRA, ABERTURA CENTRAL MONTAGEM HORIZONTAL PARALELA	2	Central break	73	2000	32	N	MANUAL	-	e	N	-10	1	Horizontal paralel	2470mm
GSH003/608	E-CEARÁ	6783064	6783064	150756	SECCIONADOR, TRIPOLAR, 72.5KV, 1250A, COMANDO MANUAL, SEM LAMINA DE TERRA, ABERTURA LATERAL MONTAGEM VERTICAL INVERTIDA ALTA	2	Lateral break	73	1250	32	N	MANUAL	-	e	N	-10	1	Vertical	10400mm
GSH003/609	E-CEARÁ	6803004	6803004	150766	SECCIONADOR, TRIPOLAR, 72.5KV, 2000A, COMANDO MANUAL, COM LÁMINA DE TERRA, ABERTURA CENTRAL MONTAGEM VERTICAL ALTA	2	Central break	73	2000	32	Y	MANUAL	MANUAL	e	N	-10	1	Vertical	6000mm

TYPE CODE	COMPANY	COMPANY CODE	E4E CODE	CODE	DESCRICION	Nº Columns/pole	Type opening	Ur	Ir	Ik	ES	DS operation	ES operation	SPS class	Bus bar transfer	Minimum ambient air temperature (°C)	Ice coating (mm)	ASSEMBLY	Installation height (mm)
GSH003/300	ENEL GO	48451	150099	150099	SECCIONADOR, C/LT, S/CARGA, 3P, 72,5 KV, ABERTURA LATERAL DUPLA, 1250A, 31,5 KA,	3	Double break	72,5	1250	31,5	Y	MANUAL	MANUAL	c	N	-10	1	Horizontal	< 6000
GSH003/301	ENEL GO	48453	48453	150762	SECCIONADOR, S/LT, S/CARGA, 3P, 72,5 KV, ABERTURA LATERAL DUPLA, 1250A, 31,5 KA,	3	Double break	72,5	1250	31,5	N	MANUAL	-	c	N	-10	1	Horizontal	< 6000
GSH003/302	ENEL GO	48452	48452	150761	SECCIONADOR, C/LT, S/CARGA, 3P, 138 KV, ABERTURA LATERAL DUPLA, 1250A, 40 KA,	3	Double break	145	1250	40	Y	MOTOR	MANUAL	c	N	-10	1	Horizontal	< 6000
GSH003/303	ENEL GO	48755	48755	150100	SECCIONADOR, S/LT, S/CARGA, 3P, 138 KV, ABERTURA LATERAL DUPLA, 1250A, 40 KA,	3	Double break	145	1250	40	N	MOTOR	-	c	N	-10	1	Horizontal	< 6000
GSH003/304	ENEL GO	150982		150982	CH, 72.5KV, 1250A, MAN, S/LT, HO, 2.45m, GSH003	3	Double-Break	72,5	1250	31.5	N	Manual	-	d	N	-10	1	Horizontal	2450
GSH003/305	ENEL GO	150107		150107	CH, 72KV, 1250A, MAN, S/LT, VER, <10m, GSH3/305	2	Lateral	72,5	1250	31,5	N	Manual	-	D	N	-10	1	Vertical	<10000
GSH003/306	ENEL GO	150775		150775	CH, 145KV, 1250A, MOT, S/LT, HOR, GSH003/306	3	Reverse Vertical Break	145	1250	40	N	Motor	-	c	N	-10	1	Horizontal	< 10000
GSH003/307	ENEL GO	150821		150821	CH, 145KV, 1250A, MOT, S/LT, HOR, GSH003/307	3	Lateral Double-Break	145	1250	31,5	N	Motor	-	c	N	-10	1	Horizontal	< 10000



Application Areas

Perimeter: Global

Staff Function: -

Service Function: -

Business Line: Infrastructure & Networks

TYPE CODE	COMPANY	CODE	DESCRIPCION	Nº Columns/pole	Type opening	Ur	lr	lk	ES	DS operation	ES operation	SPS class	Bus bar transfer	Minimum ambient air temperature	Ice coating (mm)	ASSEMBLY	Installation height (mm)
GSH003/800	E-CHILE	150049	DESC 3F 245KV-2000A SPT HORIZ	2	Central break	245	2000	40	N	MOTOR	-	c	-	-10	10	Horizontal paralel	3000 mm
GSH003/801	E-CHILE	150065	DESC 3F 245KV-2000A CPT HORIZ	2	Central break	245	2000	40	Y	MOTOR	MOTOR	c	-	-10	10	Horizontal paralel	3000 mm
GSH003/802	E-CHILE	150066	DESC 3F 245KV-3150A SPT HORIZ	2	Central break	245	3150	40	N	MOTOR	-	c	-	-10	10	Horizontal paralel	3000 mm
GSH003/803	E-CHILE	150067	DESC 3F 245KV-3150A CPT HORIZ	2	Central break	245	3150	40	Y	MOTOR	MOTOR	c	-	-10	10	Horizontal paralel	3000 mm
GSH003/804	E-CHILE	150006	DESC TRIF 145KV 2000A 40kA MOTOR MON	2	Central break	145	2000	40	N	MOTOR	-	c	-	-10	10	Horizontal paralel	3000 mm
GSH003/805	E-CHILE	150068	DESC 3F 145KV 2000A CPT HORIZ	2	Central break	145	2000	40	Y	MOTOR	MOTOR	c	-	-10	10	Horizontal paralel	3000 mm
GSH003/806	E-CHILE	150057	DESC 3F 145KV-2000A SPT VERT	2	Central break	145	2000	40	N	MOTOR	-	c	-	-10	10	Vertical	7000 mm
GSH003/807	E-CHILE	150069	DESC 3F 145KV-2000A CPT VERT	2	Central break	145	2000	40	Y	MOTOR	MOTOR	c	-	-10	10	Vertical	7000 mm
GSH003/808	E-CHILE	150071	DESC 3F 145KV 3150A SPT HORIZ	2	Central break	145	3150	40	N	MOTOR	-	c	-	-10	10	Horizontal paralel	3000 mm
GSH003/809	E-CHILE	150072	DESC 3F 145KV 3150A CPT HORIZ	2	Central break	145	3150	40	Y	MOTOR	MOTOR	c	-	-10	10	Horizontal paralel	3000 mm
GSH003/810	E-CHILE	170512	DESC 3F 145KV-2000A-50KA SPT	2	Central break	145	2000	50	N	MOTOR	-	c	-	-10	10	Horizontal paralel	3000 mm
GSH003/811	E-CHILE	170511	DESC 3F 145KV-2000A-50KA CPT	2	Central break	145	2000	50	Y	MOTOR	MOTOR	c	-	-10	10	Horizontal paralel	3000 mm
GSH003/812	E-CHILE	150073	DESC 3F 145KV-2000A-50KA SPT VERT	2	Central break	145	2000	50	N	MOTOR	-	c	-	-10	10	Vertical	7000 mm
GSH003/813	E-CHILE	150074	DESC 3F 145KV-2000A-50KA CPT VERT	2	Central break	145	2000	50	Y	MOTOR	MOTOR	c	-	-10	10	Vertical	7000 mm
GSH003/814	E-CHILE	150075	DESC 3F 145KV-3150A-50KA SPT HORIZ	2	Central break	145	3150	50	N	MOTOR	-	c	-	-10	10	Horizontal paralel	3000 mm
GSH003/815	E-CHILE	150076	DESC 3F 145KV-3150A-50KA CPT HORIZ	2	Central break	145	3150	50	Y	MOTOR	MOTOR	c	-	-10	10	Horizontal paralel	3000 mm
GSH003/816	E-CHILE	150077	DESC 3F 145KV-2000A SPT HORIZ MANUAL	2	Central break	145	2000	40	N	MANUAL	-	c	-	-10	10	Horizontal paralel	3000 mm
GSH003/817	E-CHILE	150078	DESC 3F 145KV-2000A CPT HORIZ MANUAL	2	Central break	145	2000	40	Y	MANUAL	MANUAL	c	-	-10	10	Horizontal paralel	3000 mm
GSH003/818	E-CHILE	150079	DESC 3F 145KV-2000A SPT VERT MANUAL	2	Central break	145	2000	40	N	MANUAL	-	c	-	-10	10	Vertical	7000 mm
GSH003/819	E-CHILE	150080	DESC 3F 145KV-2000A CPT VERT MANUAL	2	Central break	145	2000	40	Y	MANUAL	MANUAL	c	-	-10	10	Vertical	7000 mm
GSH003/820	E-CHILE	150070	DESC 3F 145KV-2000A-50kA SPT HORZ MA	2	Central break	145	2000	50	N	MANUAL	-	c	-	-10	10	Horizontal paralel	3000 mm
GSH003/821	E-CHILE	150081	DESC 3F 145KV-2000A-50kA CPT HORZ MA	2	Central break	145	2000	50	Y	MANUAL	MANUAL	c	-	-10	10	Horizontal paralel	3000 mm
GSH003/822	E-CHILE	150082	DESC 3F 145KV-2000A-50kA SPT VERT MA	2	Central break	145	2000	50	N	MANUAL	-	c	-	-10	10	Vertical	7000 mm
GSH003/823	E-CHILE	150083	DESC 3F 145KV-2000A-50kA CPT VERT MA	2	Central break	145	2000	50	Y	MANUAL	MANUAL	c	-	-10	10	Vertical	7000 mm
GSH003/824	E-CHILE	150084	DESC 1F 245KV-2000A SPT HORIZ	2	Central break	245	2000	40	N	MOTOR (1 ø)	-	c	-	-10	10	Horizontal paralel	3000 mm
GSH003/825	E-CHILE	150085	DESC 1F 245KV-2000A CPT HORIZ	2	Central break	245	2000	40	Y	MOTOR (1 ø)	MOTOR	c	-	-10	10	Horizontal paralel	3000 mm
GSH003/826	E-CHILE	150086	DESC 1F 145KV-3150A SPT HORIZ	2	Central break	145	3150	40	N	MOTOR (1 ø)	-	c	-	-10	10	Horizontal paralel	3000 mm
GSH003/827	E-CHILE	150087	DESC 1F 145KV-3150A CPT HORIZ	2	Central break	145	3150	40	Y	MOTOR (1 ø)	MOTOR	c	-	-10	10	Horizontal paralel	3000 mm
GSH003/828	E-CHILE	150088	DESC 1F 145KV-3150A-50kA SPT HORIZ	2	Central break	145	3150	50	N	MOTOR (1 ø)	-	c	-	-10	10	Horizontal paralel	3000 mm
GSH003/829	E-CHILE	150089	DESC 1F 145KV-3150A-50 kA CPT HORIZ	2	Central break	145	3150	50	Y	MOTOR (1 ø)	MOTOR	c	-	-10	10	Horizontal paralel	3000 mm
GSH003/830	E-CHILE	150007	DESC TRIF 145KV 3150A 40kA MOTOR MON	2	Central break	145	3150	40	N	MOTOR	-	c	-	-10	10	Vertical	7000 mm



Application Areas

Perimeter: Global

Staff Function: -

Service Function: -

Business Line: Infrastructure & Networks

TYPE CODE	COMPANY	CODE	DESCRIPCION	Nº Columns/pole	Type opening	Ur	Ir	lk	ES	DS operation	ES operation	SPS class	Bus bar transfer	Minimum ambient air temperature	Ice coating (mm)	ASSEMBLY	Installation height (mm)
GSH003/700	CODENSA	6788913	ECCIONADOR 145KV 2000A 40KA MANUAL SCPT HOR	2	Central break	145	2000	40	N	MANUAL	--	c	N	-10	10	Horizontal paralel	2150 mm
GSH003/701	CODENSA	6787659	ECCIONADOR 145KV 2000A 40KA MANUAL CCPT HOR	2	Central break	145	2000	40	Y	MANUAL	MANUAL	c	N	-10	10	Horizontal paralel	2150 mm
GSH003/702	CODENSA	150614	SECCIONADOR 145KV 2000A 40KA M SCPT HORZ	2	Central break	145	2000	40	N	MOTOR	MANUAL	c	N	-10	10	Horizontal paralel	2150 mm
GSH003/703	CODENSA	150615	SECCIONADOR 145KV 2000A 40KA M CCPT HORZ	2	Central break	145	2000	40	Y	MOTOR	MANUAL	c	N	-10	10	Horizontal paralel	2150 mm

TYPE CODE	COMPANY	COMPANY CODE	E4E CODE	CODE	DESCRIPCION	Nº Columns/pole	Type opening	Ur	Ir	lk	ES	DS operation	ES operation	SPS class	Bus bar transfer	Minimum ambient air temperature	Ice coating (mm)	ASSEMBLY	Installation height (mm)
GSH003/500	E-PERU	6792662	150570	6792662	SECC.TRIP.60KV.1250A.40KA S/PT.HORZ.EXT	2	Central break	72,5	1250	40	N	MOTOR	-	e	Y	-10	1	Horizontal paralel	2300 mm
GSH003/501	E-PERU	6792646	150569	6792646	SECC.TRIP.60KV.1250A.40KA C/PT.HORZ.EXT	2	Central break	72,5	1250	40	Y	MOTOR	MANUAL	e	Y	-10	1	Horizontal paralel	2300 mm
GSH003/502	E-PERU	6760960	150546	6760960	SECC.TRIP.60KV.1250A.31,5KA S/PT.HORZ.EXT	2	Central break	72,5	1250	31,5	N	MOTOR	-	e	N	-10	1	Horizontal paralel	2300 mm
GSH003/503	E-PERU	6757158	150507	6757158	SECC.TRIP.60KV.1250A. APERT.CENTRAL	2	Central break	72,5	1250	31,5	Y	MOTOR	MANUAL	e	N	-10	1	Horizontal paralel	2300 mm
GSH003/504	E-PERU	6798993	150574	6798993	SECC. POT. TRIPOLAR, 220 KV, 1250A S/PT	2	Central break	245	2000	40	N	MOTOR	--	e	Y	-10	1	Horizontal paralel	2300 mm
GSH003/505	E-PERU	6798994	150575	6798994	SECC. POT. TRIPOLAR, 220 KV, 1250A C/PT	2	Central break	245	2000	40	Y	MOTOR	MOTOR	e	Y	-10	1	Horizontal paralel	2300 mm
GSH003/506	E-PERU	6806310	150580	6806310	SECC. POT. TRIPOLAR, 72,5 KV, 1250A S/PT VERT	2	Vertical-break	72,5	1250	31,5	N	MOTOR	-	e	Y	-10	1	Vertical (Exterior)	4200 mm
GSH003/507	E-PERU	6806311	150581	6806311	SECC. POT. TRIPOLAR, 72,5 KV, 1250A C/PT VERT	2	Vertical-break	72,5	1250	31,5	Y	MOTOR	MANUAL	e	N	-10	1	Vertical (Exterior)	4200 mm
GSH003/508	E-PERU	6761914	150551	6761914	SECC.TRIP.60KV.1250A.31.5KA.C/PT.VER.INT	2	Vertical-break	72,5	1250	31,5	Y	MOTOR	MOTOR	e	N	-10	1	Vertical (Interior)	4200 mm
GSH003/509	E-PERU	6761915	150552	6761915	SECC.TRIP.60KV.1250A.31.5KA.S/PT.VER.INT	2	Vertical-break	72,5	1250	31,5	N	MOTOR	-	e	Y	-10	1	Vertical (Interior)	4200 mm
GSH003/510	E-PERU	6797487	150573	6797487	SECC.TRIP.60KV.2000A.40KA.S/PT.HORZ.EXT	2	Centre-break	72,5	2000	40	N	MOTOR	-	e	Y	-10	1	Horizontal paralel	2300 mm



Application Areas

Perimeter: Global

Staff Function: -

Service Function: -

Business Line: Infrastructure & Networks

TYPE CODE	COMPANY	CODE	DESCRIPCION	Nº Columns/pole	Type opening	Ur	lr	lk	ES	DS operation	ES operation	SPS class	Bus bar transfer	Minimum ambient air temperature	Ice coating (mm)	ASSEMBLY	Installation height (mm)
GSH003/400	EDESUR	0104-0049	SECC 132 KV, 2000 A, SIN PUESTA A TIERRA	3	Central break	145	2000	31,5	N	MOTOR	--	c	N	-10	10	Horizontal paralel	2250 mm
GSH003/401	EDESUR	0104-0367	SECC 132 KV 800 A SIN PUESTA A TIERRA	2	Central break	145	800	31,5	N	MOTOR	--	c	N	-10	10	Horizontal paralel	2250 mm
GSH003/402	EDESUR	0104-0361	SECC 132 KV 800 A. MONTAJE FILA INDIA, SIN PUESTA A TIERRA	2	Central break	145	800	31,5	N	MOTOR	--	c	N	-10	10	Horizontal in line	2250 mm
GSH003/403	EDESUR	0104-0048	SECC CON PUESTA A TIERRA, DE MONTAJE PARALELO, 132 KV. 800 A.	2	Central break	145	800	31,5	Y	MOTOR	MANUAL	c	N	-10	10	Horizontal paralel	2250 mm
GSH003/404	EDESUR	0104-0424	SECC 132 KV, 800 A, CON PUESTA A TIERRA, DE MONTAJE POLOS PARALELO	2	Central break	145	800	31,5	Y	MOTOR	MANUAL	d	N	-10	10	Horizontal paralel	2250 mm
GSH003/405	EDESUR	0104-0366	SECC SIN PUESTA A TIERRA, 132 KV. 2000 A	2	Central break	145	2000	31,5	N	MOTOR	--	c	N	-10	10	Horizontal in line	2250 mm
GSH003/406	EDESUR	0104-0401	SECC 132 KV, 2000 A, CON PUESTA A TIERRA, MONTAJE PARALELO	2	Central break	145	2000	31,5	Y	MOTOR	MANUAL	c	N	-10	10	Horizontal paralel	2250 mm
GSH003/407	EDESUR	0104-0382	SECC 132 KV 3150 A. MONTAJE FILA INDIA, SIN PUESTA A TIERRA	2	Central break	145	3150	31,5	N	MOTOR	--	c	N	-10	10	Horizontal in line	2250 mm
GSH003/408	EDESUR	0104-0362	SECC 220 KV 800 A. MONTAJE FILA INDIA, SIN PUESTA A TIERRA	2	Central break	245	800	40	N	MOTOR	--	c	N	-10	10	Horizontal in line	2250 mm
GSH003/409	EDESUR	0104-0363	SECC 220 KV 2000 A, MONTAJE FILA INDIA, SIN PUESTA A TIERRA	2	Central break	245	2000	40	N	MOTOR	--	c	N	-10	10	Horizontal in line	2250 mm
GSH003/410	EDESUR	0104-0364	SECC 220 KV 2000 A, CON PUESTA A TIERRA, MONTAJE POLOS PARALELOS.	2	Central break	245	2000	40	Y	MOTOR	MANUAL	c	N	-10	10	Horizontal paralel	2250 mm
GSH003/411	EDESUR	0104-0386	SECC 220 KV, 3150 A, CON PUESTA A TIERRA, DE MONTAJE DE POLOS	2	Central break	245	3150	40	Y	MOTOR	MANUAL	c	N	-10	10	Horizontal paralel	2250 mm
GSH003/412	EDESUR	0104-0394	SECC 220 KV, 3150 A, MONTAJE DE POLOS PARALELOS, SIN PUESTA A TIERRA.	2	Central break	245	3150	40	N	MOTOR		c	N	-10	10	Horizontal paralel	2250 mm
GSH003/413	EDESUR	0104-0385	SECC 220 KV, 3150 A, MONTAJE FILA INDIA, SIN PUESTA A TIERRA.	2	Central break	245	3150	40	N	MOTOR		c	N	-10	10	Horizontal in line	2250 mm

**Application Areas**

 Perimeter: *Global*

Staff Function: -

Service Function: -

 Business Line: *Infrastructure & Networks*

TYPE CODE	COMPANY	CODE	DESCRIPCION	Nº Columns/pole	Type opening	Ur	Ir	Ik	ES	DS operation	ES operation	SPS class	Bus bar transfer	Minimum ambient air temperature	Ice coating (mm)	ASSEMBLY	Installation height (mm)
GSH003/100	ENEL RO	150001	Separator tripolar 123kV 1600A 40kA cu CLP in montaj	2	Central break	123	1600	40	N	MANUAL	-	d	N	-30	22	Horizontal paralel	2300/3200 mm
GSH003/101	ENEL RO	150002	Separator tripolar 123kV 1600A 40kA cu 2 CLP in montaj	2	Central break	123	1600	40	N	ELECTRIC	-	d	N	-30	22	Horizontal paralel	2300/3200 mm
GSH003/102	ENEL RO	150003	Separator tripolar 123kV 1600A 40kA fara CLP in montaj	2	Central break	123	1600	40	Y	MANUAL	MANUAL	d	N	-30	22	Horizontal paralel	2300/3200 mm
GSH003/103	ENEL RO	150004	Separator tripolar 123kV 1600A 40kA fara CLP in montaj	2	Central break	123	1600	40	Y	ELECTRIC	ELECTRIC	d	N	-30	22	Horizontal paralel	2300/3200 mm
GSH003/104	ENEL RO	150005	Separator tripolar 123kV 1600A 40kA cu CLP in montaj	2	Central break	123	1600	40	YY (2ESs)	MANUAL	MANUAL	d	N	-30	22	Horizontal paralel	2300/3200 mm
GSH003/105	ENEL RO	150006	Separator tripolar 123kV 1600A 40kA 2 CLP in montaj p	2	Central break	123	1600	40	YY (2ESs)	ELECTRIC	ELECTRIC	d	N	-30	22	Horizontal paralel	2300/3200 mm
GSH003/106	ENEL RO	150007	Separator tripolar 123kV 1600A 40kA fara CLP in montaj	2	Central break	123	1600	40	N	MANUAL	-	d	N	-30	22	Horizontal in line	2300/3200 mm
GSH003/107	ENEL RO	150008	Separator tripolar 123kV 1600A 40kA fara CLP in montaj	2	Central break	123	1600	40	N	ELECTRIC	-	d	N	-30	22	Horizontal in line	2300/3200 mm
GSH003/108	ENEL RO	150009	Separator tripolar 123kV 1600A 40kA cu CLP in montaj	2	Central break	123	1600	40	Y	MANUAL	MANUAL	d	N	-30	22	Horizontal in line	2300/3200 mm
GSH003/109	ENEL RO	150010	Separator tripolar 123kV 1600A 40kA cu CLP in montaj	2	Central break	123	1600	40	Y	ELECTRIC	ELECTRIC	d	N	-30	22	Horizontal in line	2300/3200 mm
GSH003/110	ENEL RO	150011	Separator tripolar 123kV 1600A 40kA cu 2 CLP in montaj	2	Central break	123	1600	40	YY (2ESs)	MANUAL	MANUAL	d	N	-30	22	Horizontal in line	2300/3200 mm
GSH003/111	ENEL RO	150012	Separator tripolar 123kV 1600A 40kA cu 2 CLP in montaj	2	Central break	123	1600	40	YY (2ESs)	ELECTRIC	ELECTRIC	d	N	-30	22	Horizontal in line	2300/3200 mm
GSH003/112	ENEL RO	150013	Separator monopolar 123kV 1600A 40kA cu CLP coman	2	Central break	123	1600	40	Y	MANUAL	MANUAL	d	N	-30	22	Single Phase	2300 mm
GSH003/113	ENEL RO	150014	Separator monopolar 123kV 1600A 40kA cu CLP coman	2	Central break	123	1600	40	Y	ELECTRIC	ELECTRIC	d	N	-30	22	Single Phase	2300 mm

- Note: "MOTOR (1 ø)" means 3 motors, 1 for each phase
- Note: "YY (2 EEs)" means 2 earthing switches, located on the opposite ends of the disconnecter
- Note \*\*\* This disconnecter for Enel Ceará: there is three kinds of pole, shaped of truncated pyramid of rectangular outside beam with the following equations from the top:

Pole 1

 Nominal stress side pole 1:  $28.h + 140$ 

 Secondary stress side pole 1:  $20.h + 182$ 

Pole 2

 Nominal stress side pole 2:  $28.h + 170$ 

 Secondary stress side pole 2:  $20.h + 224$ 

Pole 3

 Nominal stress side pole 3:  $28.h + 230$ 

 Secondary stress side pole 3:  $20.h + 308$